

Einzelheit / Detail X
1:5

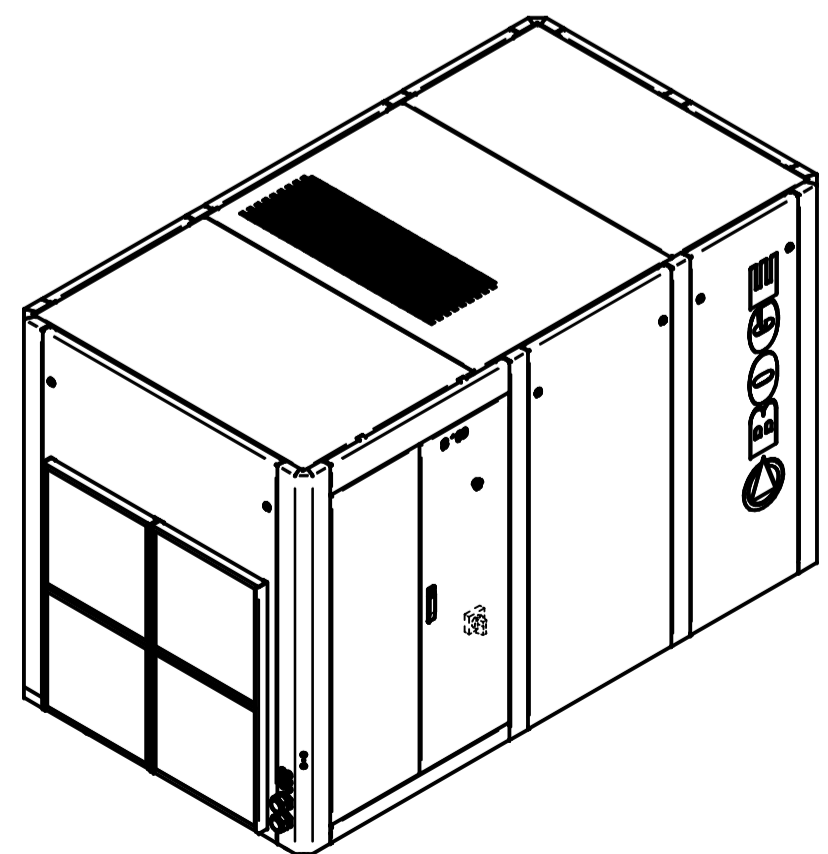

1:30

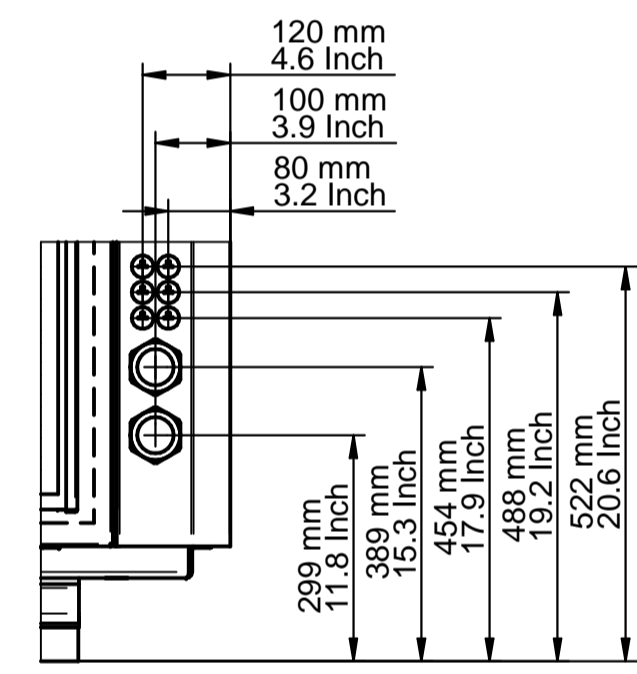
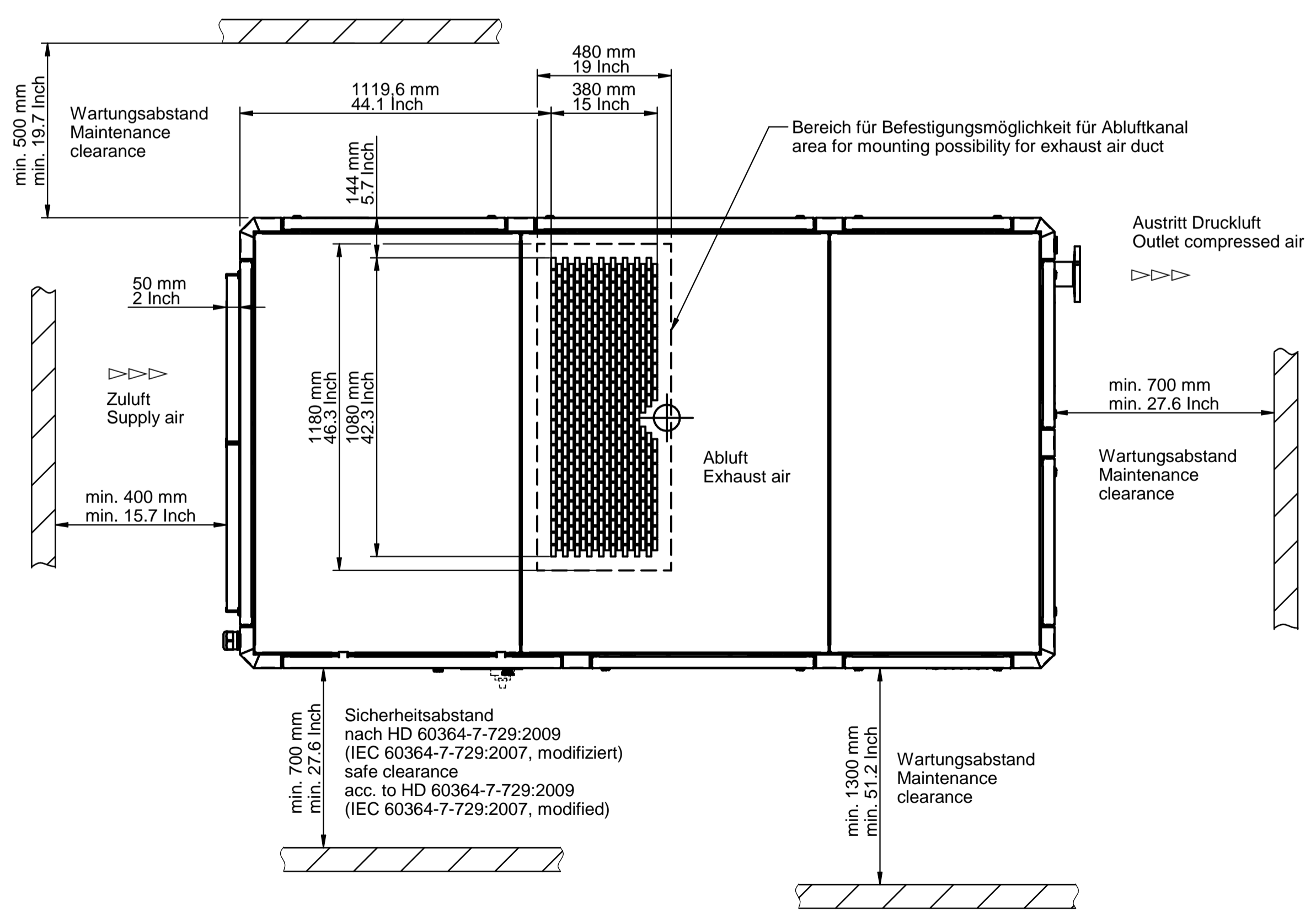

Einzelheit / Detail Y
1:10

1. Gewicht Schallgedämmt / Superschallgedämmt, ohne Optionen
Weight silenced / Super silenced, without option
2. Statische Belastungen pro Auflager
Static loads per abutment
3. Kühlluftbedarf (Volumenströme der Luftkühlung + Verdichteransaugung)
Cooling air requirement (volume flow of air cooling + compressor intake)
4. Erforderlicher Kühlluftstrom der Ventilation
Required cooling air flow for ventilation
5. Erforderlicher Querschnitt Zuluft bei künstlicher Belüftung
Required cross section supply air for artificial ventilation

Bei Einbau von Widerständen in Zuluft und/oder Abluft sind die Querschnitte, Kühlluftbedarfe, Volumenströme des Ventilators entsprechend zu erhöhen.
When installing resistors in supply and/or exhaust the cross sections, cooling air requirements, flow rates of the fan should be increased accordingly.

Technische Daten / Technical data					
	1.	2.	3.	4.	5.
Maschine / type	kg	N/cm ²	m ³ /h	nach / acc. VDMA 4363:1978	nach / acc. VDMA 4363:1978
S 111-4 LF	3550 / 3600	58 / 59	16 250	35 030	3,3
S 132-4 LF	3650 / 3700	59 / 60	16 450	41 850	3,9
S 160-4 LF	3750 / 3800	60 / 61	21 650	51 310	4,8
Maschine / type	lbs	psi	ft ³ /h	ft ³ /h	ft ²
S 111-4 LF	7830 / 7940	85 / 86	573 900	1 237 100	36
S 132-4 LF	8050 / 8160	86 / 87	580 950	1 478 000	42
S 160-4 LF	8270 / 8380	88 / 89	764 600	1 812 000	52

Technische Änderungen vorbehalten. All rights reserved for technical changes.		Kürzeltyp / Drawing type		Dokumententyp / Document status	
Datum / Date		Benennung / Designation		1:15	
Ersatz / Replaces		Masszeichnung		Freigegeben	
Erstellt / Created		S 111-4 LF - S 160-4 LF		luftgekühlt / aircooled	
Geprüft / Checked		M1200.1141 DE-EN		1	
Freigegeben / Released		www.boege.com		1 of 1	
DOK-Id: 2222091/SDM000/02		Ersatz / Replacement for		Ersatz / Replacement for	

