



# INSTRUCTION MANUAL

PORTABLE  
SCREW COMPRESSOR

**FAC-185P**  
**FACF-150P**  
**FACG-125P**

Please be sure to read this manual  
before using this machine.

# Preface

Thank you for having selected our "FSCURTIS" product.

- ◆ This manual explains about the proper operation and daily inspection and maintenance of this machine.
- ◆ In order to use a machine safely, people with sufficient knowledge and sufficient technology need to deal with it.
- ◆ Before operating the unit, read the manual carefully, fully understand its operation and maintenance requirement. Maintain "SAFETY OPERATION AND PROPER MAINTENANCE OF THE UNIT".

Be sure to follow safety warnings and cautions given in the manual. Unsafe operation could cause serious injury or death.

- ◆ For details of handling, maintenance and safety of the engine, see the Engine Operation Manual.
- ◆ Keep the manual available at all times for the operator or safety supervisor.
- ◆ If the manual is lost or damaged, place an order with your dealer for another copy.
- ◆ Be sure that the manual is included with the unit when it is handed over to another user.
- ◆ There may be some inconsistency in detail between the manual and the actual machine due to improvements of the machine. Ask your dealer if you have any questions or problems.
- ◆ If you have any questions about the unit, please inform us the model and serial number. A plate stamped with the model and serial number is attached to side of the unit.

PORTABLE COMPRESSOR	
MODEL	<input type="text"/>
SER. NO.	<input type="text"/>
NORMAL OPERATING PRESSURE	<input type="text"/> MPa
NET DRY MASS	<input type="text"/> kg
OPERATING MASS	<input type="text"/> kg
 MADE IN JAPAN	

A090188

- ◆ Each illustrated figure (Fig.) has a number (for instance, A090188) at the right bottom. This number is not a part number, but it is used only for our reference number.

# Table of Contents





<b>1. Safety</b> .....	<b>1-1</b>
1.1 Caution before Operation .....	1-2
1.2 Caution during Operation .....	1-6
1.3 Caution during Inspection and Maintenance .....	1-9
1.4 Safety Warning Labels .....	1-12
<b>2. Part Names</b> .....	<b>2-1</b>
2.1 Unit Appearance and Part Names .....	2-1
2.2 Internal Components and Part Names .....	2-2
<b>3. Installation</b> .....	<b>3-1</b>
3.1 Transportation .....	3-1
3.2 Handling the Drawbar .....	3-2
3.3 Towing the Unit .....	3-4
3.4 Location and Installation .....	3-5
<b>4. Operation</b> .....	<b>4-1</b>
4.1 Instrument panel .....	4-1
4.2 Door .....	4-2
4.3 Check before Starting the Unit .....	4-2
4.4 Unit Operation .....	4-7
4.5 Stopping Procedures .....	4-12
<b>5. Periodic Inspection/Maintenance</b> .....	<b>5-1</b>
5.1 Important items as Periodic and Maintenance or after Maintenance .....	5-1
5.2 Daily Inspection and keeping Operation Log .....	5-2
5.3 Periodic Inspection List .....	5-3
5.4 Periodic Replacement of Parts .....	5-5
5.5 Maintenance .....	5-6
5.6 Inspection on Separator Receiver Tank .....	5-14
<b>6. Maintenance/Adjustment</b> .....	<b>6-1</b>
6.1 Maintenance of Battery .....	6-1
6.2 Troubleshooting .....	6-3
<b>7. Storage of the Unit</b> .....	<b>7-1</b>
7.1 Preparation for Long-term Storage .....	7-1
<b>8. Specifications</b> .....	<b>8-1</b>
8.1 Specifications .....	8-1
8.2 Outline drawing .....	8-2
<b>9. Wiring Diagram</b> .....	<b>9-1</b>
<b>10. Piping Diagram</b> .....	<b>10-1</b>

# 1. Safety

---

This manual explains and illustrates general requirements for safety.

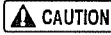
Read all safety requirements carefully and fully understand the contents before starting the machine.

For your better recognition, according to the degree of potential danger, safety messages are classified into three hierarchical categories, namely, , , and  with a caution symbol —attached to each message.

When one of these messages is shown, please take preventive measures and carry out “SAFETY OPERATION AND PROPER MAINTENANCE OF THE UNIT”.



**DANGER** indicates an imminently hazardous situation which, if not avoided, will result in death or serious injury. This signal word is to be limited to the most extreme situations.



**WARNING** indicates a potentially hazardous situation which, if not avoided, could result in death or serious injury.



**CAUTION** indicates a potentially hazardous situation which, if not avoided, may result in minor or moderate injury. It may also be used to alert against unsafe practices.



**IMPORTANT** indicates important caution messages for the performance or durability of the unit.

Follow warnings mentioned in this manual. This manual does not describe all safety items. We, therefore, advise you to pay special attention to all items (even though they may not be described in the manual) for your safety.

# 1.Safety

## 1.1 Caution before Operation



**Compressed air is prohibited to be used for human respiration**

- Compressed air by this unit contains poisonous materials. Absorption of the compressed air can cause serious injury. Never provide this compressed air for human respiration.
- This unit is not designed to be used for working chambers pressurized by compressed air such as respiratory air provided to persons working inside wells and tunnels such as pneumatic engineering method and pneumatic caisson method. Should this unit stop operation due to trouble, it can cause death and serious injury to the working persons. Refrain from using the compressed air for such pneumatic engineering method or pneumatic caisson method.

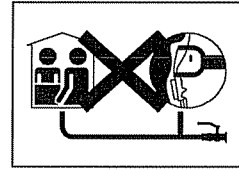

TR0201-1

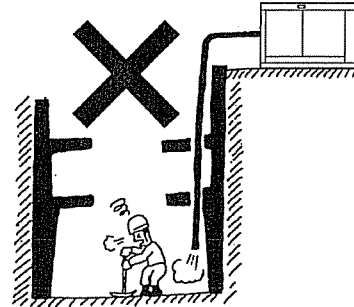

A080001



**Ventilation**

- Exhaust gas from the engine is poisonous, and could cause death when inhaled. Avoid using the machine in an insufficiently ventilated building or tunnel.

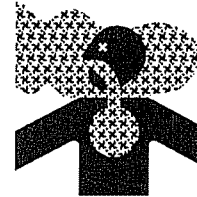

PC002



**Follow the safety instructions**

- Read each instruction plate which is displayed in the manual or on the unit carefully, understand its content and follow the indications thereof.
- Keep the Safety Warning labels clean. When they are damaged or missing, apply new ones.
- Do not modify the machine without prior approval. The safety may be compromised, functions may be deteriorated, or machine life may be shortened.
- Never use the unit for the purpose of compression of gases other than air, or as a vacuum pump. Otherwise, serious accidents may occur.

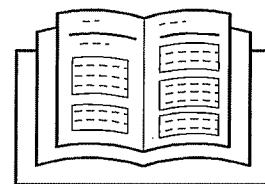

TR0086



**Maintain both physical and mental health**

- Do not operate the machine when you are tired or drunk or under the influence of drugs. Otherwise, a hasty conclusion or careless handling may cause unexpected injury or accident. Manage your physical and mental health and be cautious in handling the machine.

# 1.Safety

## WARNING

## Safety outfit

- When handling machine, do not wear;
- loose clothes
- clothes with unbuttoned sleeves
- hanging tie or scarf
- accessories such as dangling jewelry

Such outfit could be caught in the machine or dragged in the rotating portion of the machine, and this could cause a serious injury.



TR0084

## WARNING

## Transportation

- When loading and unloading unit, be sure to use the lifting bail provided on the center of the unit top.
- Never get under the unit which is suspended, because it is very dangerous.
- When unit is transferred or moved from working site, be sure to place it on truck bed, and fasten it by ropes "2" at the front and rear hooks.
- Be sure to put one set of chocks "3" to fix its wheels firmly on the truck bed. Never lift unit which is still in operation, or it could cause critical damage to each component or lead to serious accident.

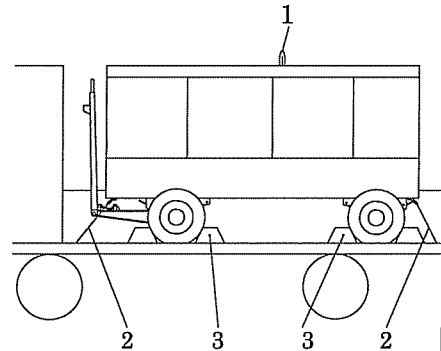

A010188

## WARNING

## Transportation

- When folding up the drawbar, be sure to engage the hook "1" to the holder "2" firmly. If the hook "1" of the drawbar "3" is disengaged from the holder "2", the drawbar "3" may fall down to cause serious injury.
- When folding up the drawbar, make sure the stopper "4" is in the locking position. If it is in disengaging position, the hook "1" can be disengaged from the holder "2", the drawbar "3" may fall down. It is very dangerous.
- When handling the hook "1", holder "2" and stopper "4", be careful not to injure your fingers.

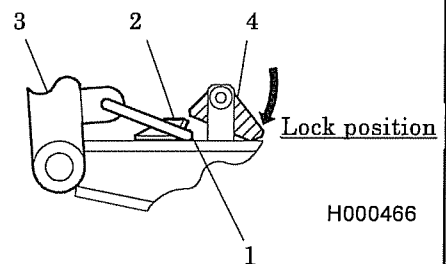

H000466

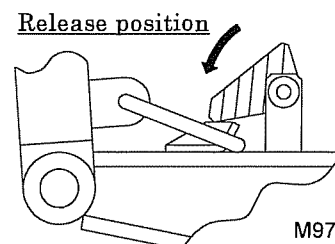

M970092

# 1.Safety

## WARNING

### Prohibition of drawing on a road

- Although the machine is designed to be drawn, drawing is allowed only in construction site.
- Towing speed should be within 20 km/h.

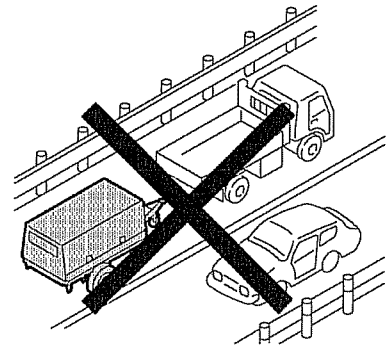

H000045

## WARNING

### Installation

- The machine has to be parked horizontally on a level place.
- In case the machine has to be parked on a slope, place it across grade so that the machine does not tend to roll downhill.
- Following grades on a slope for the machine should be observed
- Box type (skid type) : within 10°
- Trailer mounted type : within 15°
- In case if trailer mounted type, be sure to put one set of chocks "1". Be sure to pull the brake lever to brake the wheels firmly.
- The hand brake is only for parking the unit. Never use this brake as overrunning brake. In case of trailer type, be sure to put one set of chocks (1) to the wheels.

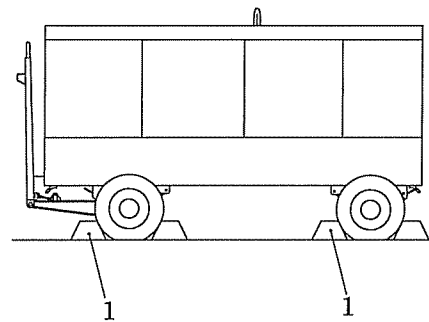

A010189

## WARNING

### Cautions of hose attachment and removal

- Piping or the hose from this machine service valve should use what can be borne enough for the discharge pressure of this machine.
- Please connect piping or a hose to this machine service valve firmly before operation and during operation. If the connection part is loosening, there is a possibility of piping or a hose separating and getting seriously injured.
- Please remove after closing a service valve and extracting pressure remained, in case piping or a hose is removed. If pressure remained should remain, a near thing blows away or there is a possibility of a hose whipping, causing a phenomenon and getting seriously injured.
- In order to use it safely, please read the handling of the work tools often used.

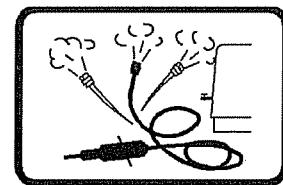

TR0088

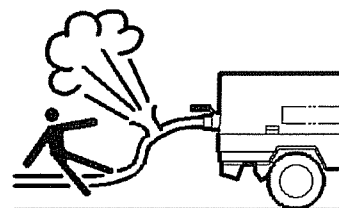

TR0303A

# 1.Safety

## WARNING

## Handling battery

- Keep flames away from battery.
- Battery may generate hydrogen gas and may explode.
- Therefore, recharging should be done at a well-ventilated place.
- Do not spark near the battery nor light a match, nor bring lit cigarette and match close to the battery.
- Do not check the battery by short-circuiting the positive and negative terminals with a metallic piece.
- Never operate the machine nor charge the batteries with the battery liquid level being kept lower than the "LOWER" level. Continuing operation at this lower level will cause deterioration of such parts as pole plates etc., and also it may cause explosion as well as reduction of battery life. Add distilled water so that the liquid level may reach the middle level between the "UPPER" and "LOWER" level without any delay.
- Do not charge the frozen battery. Otherwise it may explode. If the battery is frozen, warm it up until the battery temperature becomes 16°C to 30°C.
- Battery electrolyte is dilute sulfuric acid. In case of mishandling, it could cause skin burning.
- When you deal with a battery, please be sure to wear protection implements, such as protection glasses and a glove.
- When such battery electrolyte contacts your clothes or skin, wash it away with large amount of water immediately.
- If the battery electrolyte gets into your eyes, wash it away immediately with plenty of water and see a doctor at once, because it is feared that eyesight might be lost.
- Dispose of battery, observing local regulations.



D004

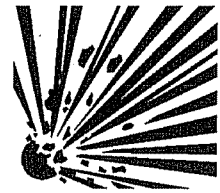

W010



TR0093



# 1.Safety

## CAUTION

### *Check before starting the unit*

- Be sure to check the unit before operation.  
When any abnormality is found, be sure to repair it before restarting the unit.
- Be sure to make daily checks before operation. If the unit is operated without prior check and without noticing its abnormality, such operation could cause seizure of components or may even cause fire.

## CAUTION

### *Protection equipments*

- Please wear protection implements, such as a helmet, protection glasses, earplugs, safety shoes, a glove, and a protection-against-dust mask, according to the contents of work for safety.

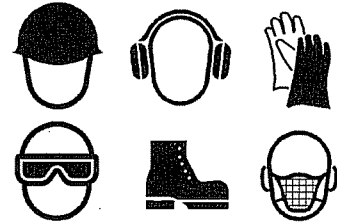

TR0085

## CAUTION

### *Safety fittings*

- Have first-aid boxes and fire-extinguishers near the unit ready for emergency situations such as injuries and a fire.
- It is advisable to have a list of phone numbers of doctors, ambulance and the fire department available in case of emergency.



TR0096

## CAUTION

### *Safety around the machine*

- Such things as unnecessary equipment and tools, cables, hoods, covers and pieces of wood which are a hindrance to the job, have to be cleaned and removed. This is because operators and/or personnel nearby may stumble on them and may be injured.
- Place safety enclosures at the entrance of and around working site to prevent children or outside people from entering the site.

## 1.2 Caution during Operation

## WARNING

### *Do not replenish compressor oil during operation*

- Do not, under any circumstance, open the oil filler cap of separator receiver tank while running or immediately after stopping operation.  
It is very dangerous because the oil filler cap could be blown off and high temperature compressed air and oil could jet out from the filler port, and cause serious injury.



WR011

# 1.Safety

## WARNING

### *Draining during operation prohibited*

- Do not, under any circumstance, open the portions below during operation:
- Separator receiver tank drain valve
- Coolant drain valve and plug
- Engine oil drain valve
- Oil cooler drain valve



PK0028

## WARNING

### *Beware of cooling fan*

- Never put your hand near the engine cooling fan during operation.  
It could cause serious injury if a hand should be caught in it.

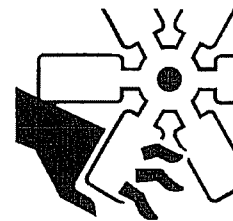

W009

## WARNING

### *Hands off from rotating parts and belts*

- Keep hands off from the rotating portion or belts while running.  
It could cause serious injuries if hands should be caught in.

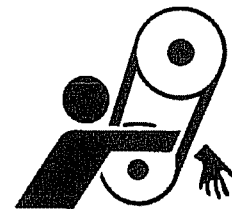

TR0304

## WARNING

### *Never direct the compressed air to people and foods*

- Never blow compressed air directly at people.  
Scattered impurities, dust, or foreign objects in the compressed air may cause skin and eyes to be seriously injured.
- Blowing compressed air on food is prohibited.

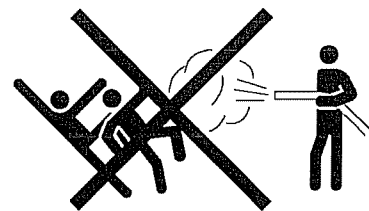

TR0092

## CAUTION

### *Do not remove radiator cap during operation*

- Do not, under any circumstance, open the radiator cap while running or immediately after stopping operation. Otherwise high temperature steam jets out and this could cause scalding.



W005

# 1.Safety

## CAUTION

### Do not touch hot parts

- Never work nearby hot portions of the machine while it is running.
- Do not touch hot portions of the machine while inspecting the machine when running.
- Such parts as engine, exhaust manifold, exhaust pipe, muffler, radiator, oil cooler, compressor, piping, separator receiver tank, and discharging pipe are especially hot, so never touch those parts, because it could cause serious burns.
- Compressor oil, coolant water, and engine oil are also very hot and dangerous to touch.  
Avoid checking or refilling them while the unit is running.



W005

## CAUTION

### Operation with compressed air supply port opened is prohibited

- Do not operate the machine with service valves and relief valve open unless air hoses and/or pipes are connected.  
High-pressurized air blows out and its air pressure could cause injury to the people nearby.
- When the machine has to be unavoidably temporarily operated with its port open, be sure to mount a silencer to reduce noise and wear protective materials such as earplugs to prevent damage to hearing.

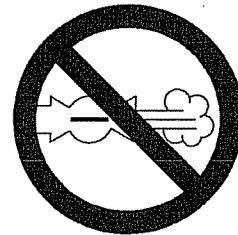

D003

## CAUTION

### Fire prevention

- Do not, under any circumstance, bring lit cigarettes or matches near such oils as engine oil and compressor oil, etc.  
They are extremely flammable and dangerous, so be careful when handling.
- Refilling oils should be done in an outdoor well-ventilated place.
- **Do not fill fuel oil up to the cap lever. When fuel tank is filled up to the cap level, fuel oil will be overfilled due to volume expansion caused by rise of ambient temperature. Further, fuel will be possibly spilled from fuel tank due to vibration caused during movement and/or transportation of machine.**
- Such parts as muffler and exhaust pipe can be extremely hot. Remove twigs, dried leaves, dried grass and waste paper, etc. from the exhaust outlet of the muffler.
- Keep a fire extinguisher available by the machine in case of a fire.



D004



W004

# 1.Safety

## 1.3 Caution during Inspection and Maintenance



**WARNING**

**Hang a "Now Checking and under Maintenance" tag**

- Remove the starter key from the starter switch before starting inspection, and hang up a "Now Checking and under Maintenance" tag where it can be easily seen. The checker must keep the key during checking and maintenance.
- Remove the negative (-) side cable from the battery. If the above procedure is neglected, and another person starts operating the machine during check or maintenance, it could cause serious injury.

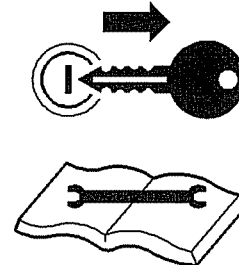

SY001



**WARNING**

**Refilling of compressor oil**

- When you refill the separator receiver tank with compressor oil, stop the engine, and make sure that the pressure gauge indicates 0 MPa and there is no residual pressure in it, and then gradually loosen the oil filler cap for refilling oil.
- Note residual pressure in the separator receiver tank could force both extremely hot compressed air and oil to jet out and you may be scalded or seriously injured.



W011



**WARNING**

**Draining separator receiver tank**

- After stopping the engine, confirm that the pressure gauge indicates 0 MPa and there is no residual pressure in it, then open the drain valve gradually to drain the compressor oil.
- Note residual pressure in the separator receiver tank could force both extremely hot compressed air and oil to jet out and you may be scalded or seriously injured.



W005



**WARNING**

**Be careful of high-pressurized air blowout**

- After stopping the engine, make sure that pressure gauge indicates 0 MPa. Even when the gauge shows 0 MPa, open a service valve and further do not fail to make sure that there is no residual pressure in the air piping. Then start such a job as repair and maintenance.
- Residual air under pressure will blow off and severely injure operator.



W011

# 1.Safety

## WARNING

### *Adjusting tension of fan belt*

- Be sure to stop the engine and remove the starter key whenever the tension of the fan belt is to be adjusted.
- Remove the negative (-) side cable from the battery.
- If the machine is running, it might catch the operator's hand into the fan belts, and this could cause a serious injury.

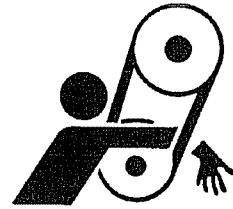

TR0304

## WARNING

### *Hands off from cooling fan*

- Be sure to stop the engine and remove the starter key whenever check or maintenance work is carried out near the cooling fan.
- If the cooling fan is rotating, it may catch the operator or part of his body into the fan, and it could cause a serious injury.

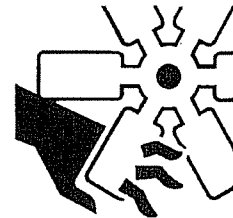

W009

## WARNING

### *Cleaning by air-blow*

- When cleaning dust accumulated in such devices as the air-filter, by blowing compressed air, wear safety glasses, etc. to protect your eyes.



M003

## CAUTION

### *Lighting apparatus*

- It is recommended to use a lamp with safety guard fitted where the site is dark. Operating the machine gropingly or by relying on one's intuition could cause unexpected accidents.
- Any lamps without safety guard are not recommended since they can be broken and they could ignite flammables such as fuel, etc.

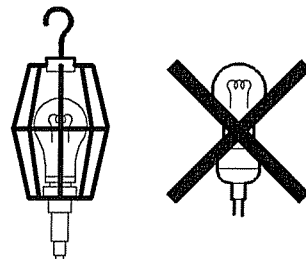

TR0206

# 1.Safety

## CAUTION

### *Taking off the radiator cap(header tank)*

- Be sure to stop the machine and allow time to cool. Then loosen the radiator cap (header tank) one notch. After the coolant water is sufficiently cooled and the inner pressure is released, take the cap off.  
If this procedure is neglected, the inner pressure can blow off the cap. Steam jetting out of the radiator could result in causing scalding. Follow this procedure under all circumstances.



W005

## CAUTION

### *Opening coolant water drain valve cap*

- Be sure to stop the engine, and let the coolant water sufficiently cool down before draining it.
- If the drain valve is opened before the coolant water is cooled enough, hot water could jet out, and it could cause scalding.



W005

## CAUTION

### *Refilling or draining of engine oil*

- After stopping the engine, wait for 10 to 20 minutes until the engine oil cools off. Then check the level of the engine oil, or refill or drain the oil.
- Engine oil is very hot and highly pressurized during or just after the operation. Hot oil could blow out of the tank and can cause scalding.



W005

## CAUTION

### *Fear of fire*

- Be sure to perform the periodical check of compressor oil and oil separator.
- Neglecting checks could cause overheat of the oil, resulting in a fire.



W004

## CAUTION

### *Disposal of waste liquid, etc.*

- Waste liquid from the machine contains harmful material. Do not discharge it onto the ground or into the river, lake or sea. Such material will contaminate the environment.
- Be sure to use a container to hold the waste liquid from the machine.
- Be sure to follow the designated regulations when disposing of oil, fuel, coolant (antifreeze), filter, battery or other harmful materials.



# 1.Safety

## 1.4 Safety Warning Labels

Following labels are attached to the machine.

Keep them clean all the time. If they are damaged or peeled off, immediately place an order with your nearest dealer for replacement, with the number indicated on the lower right corner of the label. Adhere a new one to the original place.

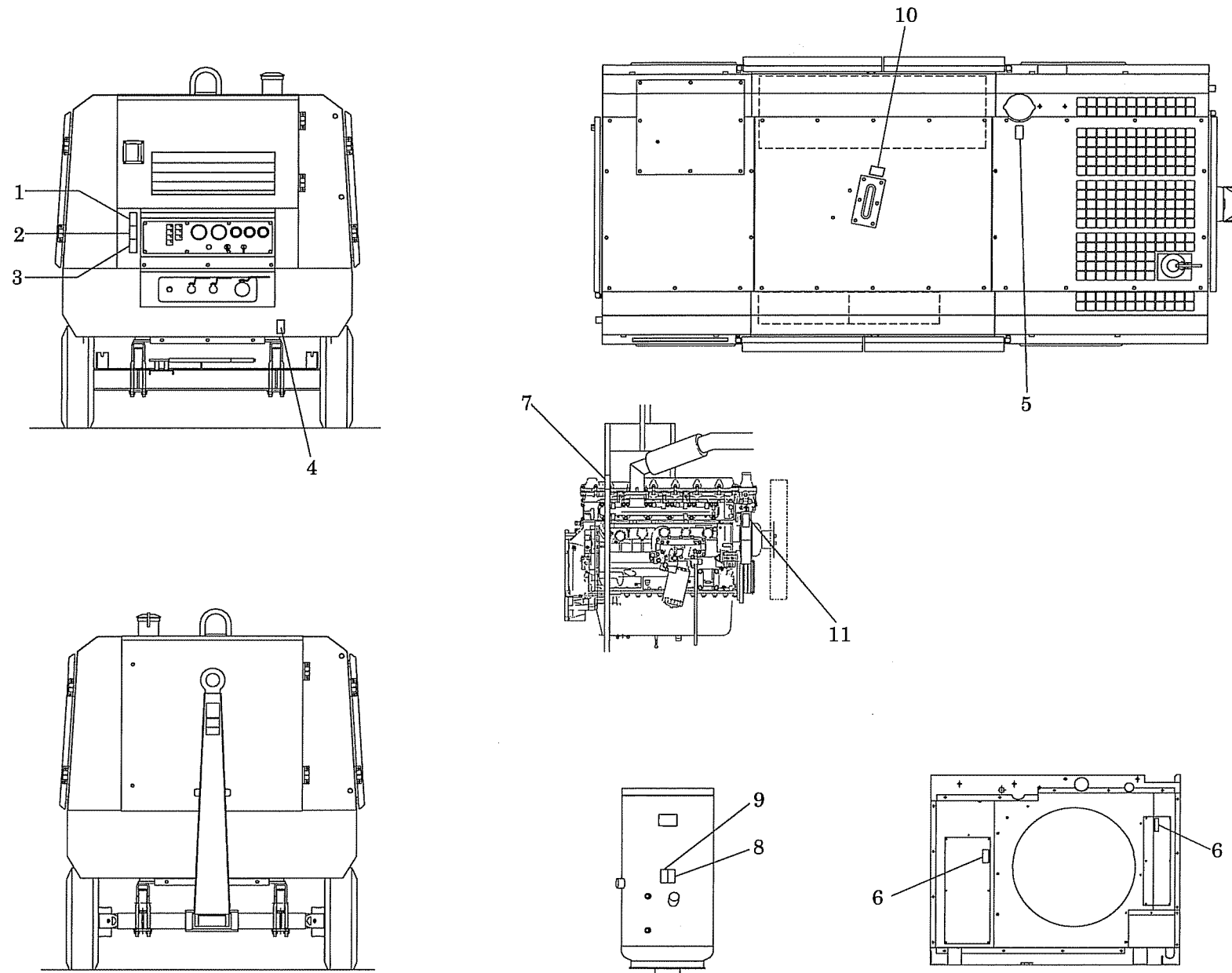

1. Caution, Do not inhale  
(39176 73600)  
2. Caution, exhaust gases  
(39176 73300)

3. Caution, hose whipping  
(39176 73400)  
4. Parking brake  
(39176 38700)

5. Caution, radiator cap  
(39176 69600)  
6. Caution, cooling fan  
(39176 73500)

7. Caution, high temp.  
(39176 69500)  
8. Caution, residual pressure  
(39176 69800)

9. Caution, fire  
(39176 69700)  
10. Lifting bail  
(39176 69300)

11. Caution, fan belt  
(39176 73800)

A020327E



## 2. Part Names

### 2.1 Unit Appearance and Part Names

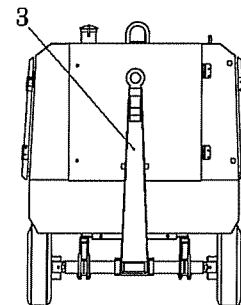
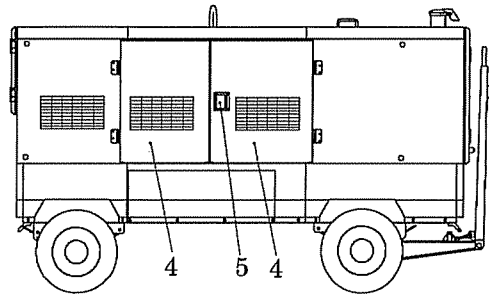
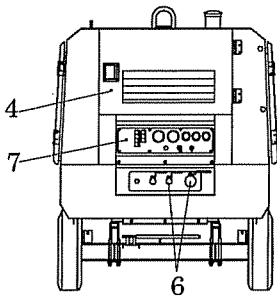
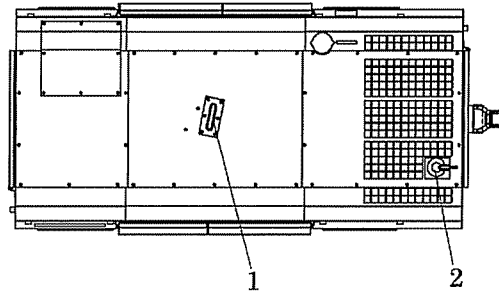
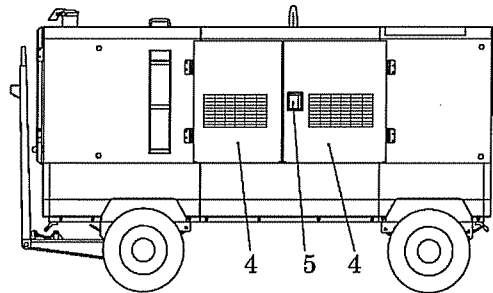

FAC-185P

A010191

- |                   |                     |
|-------------------|---------------------|
| 1. Lifting bail   | 5. Handle           |
| 2. Exhaust outlet | 6. Service valve    |
| 3. Drawbar        | 7. Instrument panel |
| 4. Door           |                     |



## 2. Part Names

### 2.2 Internal Components and Part Names

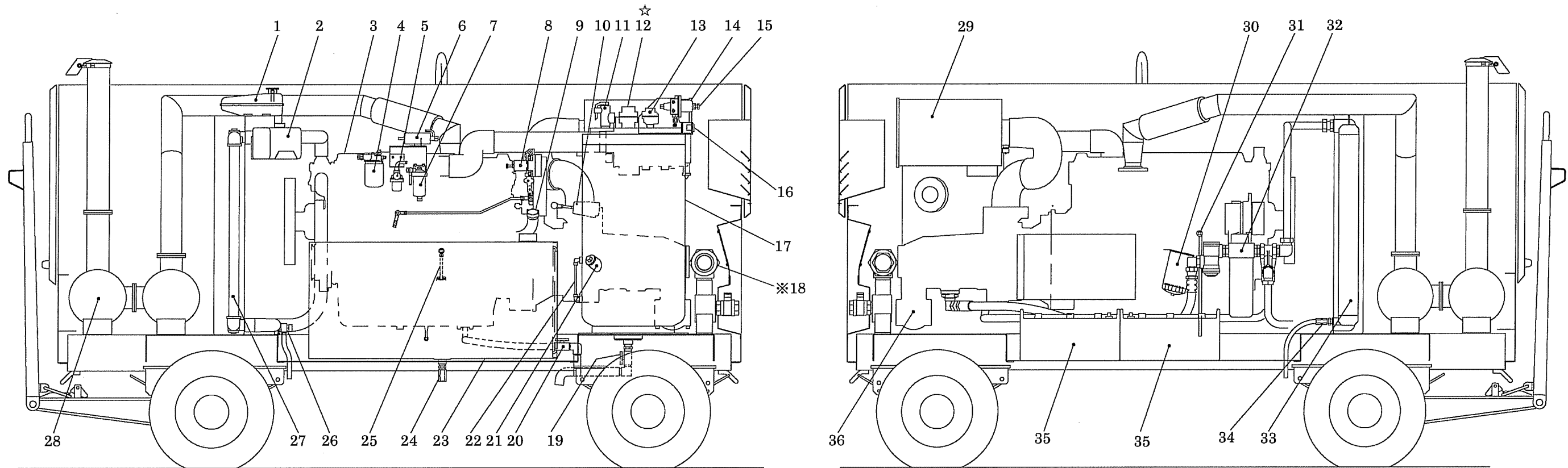

Parts marked ☆ are provided for FACF-150P, FACG-125P only.  
 Parts marked ※ are provided for FAC-185P.  
 FACF-150P, FACG-125P is different in its shape and its fitting position from the other models.

A030226

- |                                    |   |   |                                     |
|------------------------------------|---|---|-------------------------------------|
| 1. Header tank                     | 10. Unloader regulator                            | 19. Drain valve for separator receiver tank | 28. Exhaust muffler                 |
| 2. Reserve tank                    | 11. Safety valve                                  | 20. Engine oil drain valve                  | 29. Air filter element (compressor) |
| 3. Engine                          | 12. Vacuum relief valve                           | 21. Compressor oil filler port              | 30. Engine oil filter               |
| 4. Fuel filter                     | 13. Auto-relief valve                             | 22. Compressor oil level gauge              | 31. Coolant drain plug (engine)     |
| 5. Filter for electromagnetic pump | 14. Air filter element (engine)                   | 23. Fuel tank                               | 32. Compressor oil filter           |
| 6. Electromagnetic pump            | 15. Pressure regulator                            | 24. Fuel tank drain valve                   | 33. Oil cooler                      |
| 7. Water sedimenter                | 16. Differential pressure gauge for oil separator | 25. Engine oil level gauge                  | 34. Oil cooler drain valve          |
| 8. Speed regulator                 | 17. Separator Receiver Tank                       | 26. Coolant drain valve (radiator)          | 35. Battery                         |
| 9. Engine oil filler port          | 18. Pressure control valve                        | 27. Radiator                                | 36. Compressor air-end              |

# 3. Installation

## 3.1 Transportation



**WARNING**

**Transportation**

- When loading and unloading unit, be sure to use the lifting bail provided on the center of the unit top.
- Never get under the unit which is suspended, because it is very dangerous.
- When unit is transferred or moved from working site, be sure to place it on truck bed, and fasten it by ropes at the front and rear hooks.
- Be sure to put one set of chocks to fix its wheels firmly on the truck bed. Never lift unit which is still in operation, or it could cause critical damage to each component or lead to serious accident.

### Lifting up

- ① Before lifting the unit up, make sure to check the lifting bail “2” for any crack and loosened bolts.
- ② Connect the hook “1” of the crane or shackle with lifting bail “2” eye fitted at the top center of the unit, and make sure that there is no person standing around the unit. Then perform hoisting operation.
- ③ Use auxiliary ropes “3” to prevent the unit from swinging and/or twisting, giving signs and signals each other.
- ④ Select a truck or a crane with capacity sufficient for weight and size of the unit by referring to the values shown in Chapter 8 “Specifications” of the manual.
- ⑤ Never lift the unit while it is running, or this could cause a serious accident.

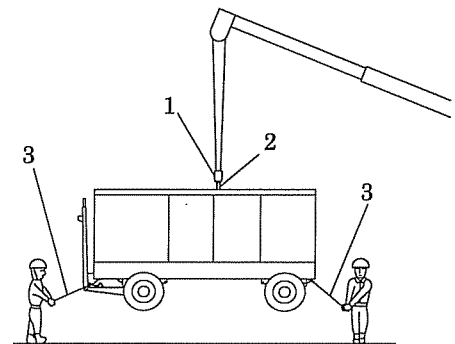

A030117

### Mounting the unit on the truck bed

- Be sure to fasten the unit with ropes “1” as shown in the figure right, and securely fix it on the truck bed.
- Be sure to put one set of chocks “2” to the wheels pull the parking brake lever it firmly after the unit is loaded on the truck bed.

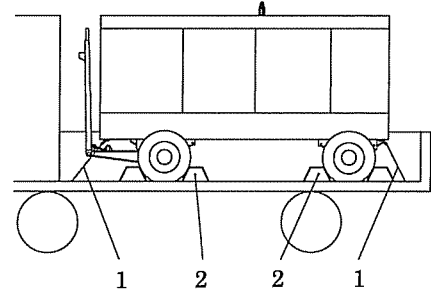

A010190

### Unloading the unit from the truck bed

- Lower the unit down onto a level place which can sustain the weight of the unit.
- After placing the unit down, put chocks “2” to lock the wheels before unfastening the crane’s shackles.

# 3. Installation

## 3.2 Handling the Drawbar



**WARNING**

### Precautions on handling drawbar

- When the drawbar "1" is raised up for transportation, be sure to secure it by engaging the drawbar hook "3" with the holder "2" without fail.
- If the drawbar hook comes off the drawbar falls down, causing serious injury.
- Therefore, make sure that the stopper "4" is locked at the lock position shown in the figure.
- When the drawbar stays at the release position shown in the figure, the hook "3" could come off the holder "2", causing the drawbar "1" to fall down.
- Handle the hook "3" holder "2" and stopper "4" so carefully to prevent your fingers from being caught and injured.

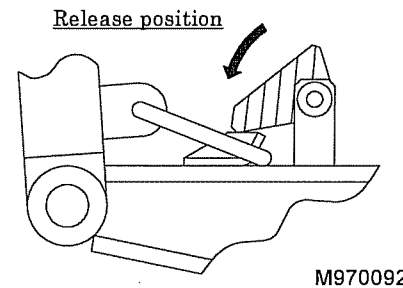
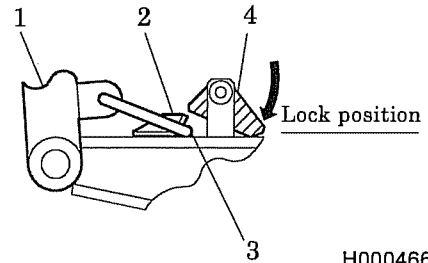

### 3.2.1 How to secure the drawbar

- ① Place the drawbar "1" to the front of the machine so that the wheel tires can be aligned.
- ② With the stopper "4" being at the lock position, raise the drawbar "1" up to the position at which the hook "3" can be engaged with the holder "2" (See Fig.1)  
If the stopper stays at the holder and so the drawbar cannot be firmly fixed. (See Fig.2)
- ③ Make sure that drawbar hook is securely engaged with the holder.
- ④ Make sure that the stopper stays at the lock position. (See Fig.1)

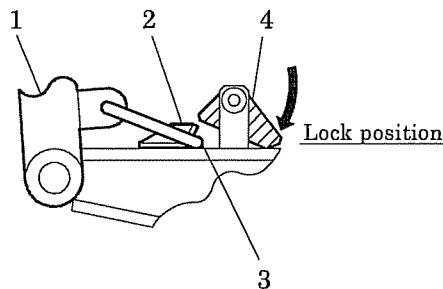
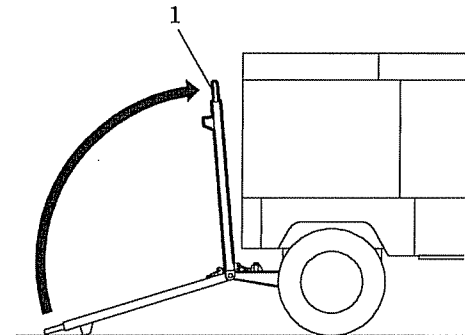

Fig.1

H000466

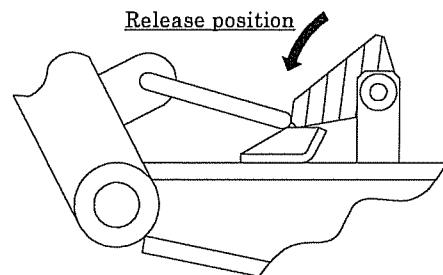

Fig.2

M970098

## 3. Installation

### 3.2.2 How to release the drawbar

- Push the fixed drawbar "1" against the machine in the direction of arrow mark.(See Fig.3)
- Turn the stopper "4" a little to make larger the clearance between stopper "4" and holder "2" than the diameter of the hook "3" .
- Release the hook from the holder "2" through the clearance.
- Lower the drawbar.
- Return the stopper "4" to the lock position.

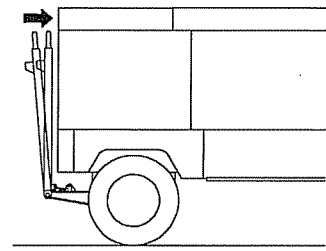
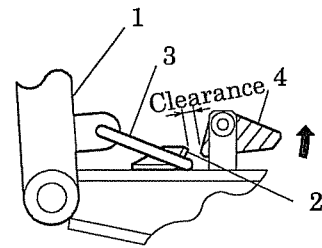

Fig.3



M970095

## 3. Installation

### 3.3 Towing the Unit

#### WARNING

- When towing unit, make sure there is no person or obstacle at both front and rear sides and under the unit.  
Although the machine is designed to be drawn, drawing is allowed only in construction site.
- Towing speed should be within 20 km/h.

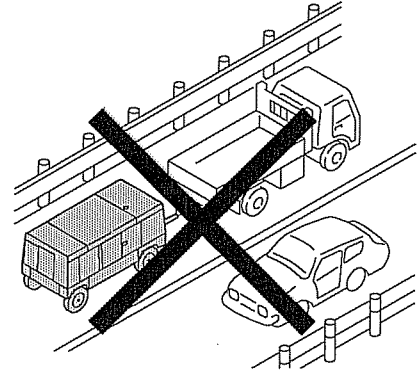

H000467

#### CAUTION

#### *Caution for towing unit*

- Be sure to use a vehicle with enough capacity to tow the unit in operating weight.
- Standard pressure for a tire is at 0.45 MPa (4.6 kgf/cm<sup>2</sup>).
- Be sure not to use wrong size or type of tire in changing.
- Make sure that the end of the drawbar is so surely and firmly connected to the coupler of the towing vehicle that the disconnection may not occur while the unit is being towed.
- Make sure if there is no deform or damage on the drawing vehicle and the drawbar of the unit.
- Be sure to keep your hand or finger away from any part of the coupling device when coupling or uncoupling a drawing device to a draw bar.
- Be sure to drive the drawing vehicle safely, avoiding dangerous place or ground, if any.
- If you do not follow the above instructions, it could cause serious injury or big damage.

# 3. Installation

## 3.4 Location and Installation

**WARNING**

**Ventilation**

- Exhaust gas from the engine is poisonous, and could cause death when inhaled. Avoid using the machine in an insufficiently ventilated building or tunnel.
- Do not position the exhaust gas outlet in direction of a person or a house.

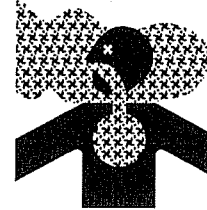

PC002

- The machine should be operated in following conditions:
  - **Ambient temperature** ..... **-15°C to +40°C**
  - **Humidity** ..... **Less than 90%**
  - **Altitude** ..... **Lower than 1,500 m above sea level**
- Install the machine in a place with good ventilation, lower temperature and with surroundings as dry as possible.
- If more than two machines are placed parallel in operation, keep enough distance so that exhaust air from one machine does not effect the other one.
- Also, a machine has to be installed in the environment where fresh air is always available.
- Keep enough space around the unit for inspection and maintenance access.

### 3.4.1 Installation

**WARNING**

- The machine has to be parked horizontally on a level place.
- In case the machine has to be parked on a slope, place it across grade so that the machine does not tend to roll downhill.
- Following grades on a slope for the machine are recommended within 15 degrees
- In case of trailer type, be sure to put one set of chocks "1" to the wheels.
- This parking brake is a device exclusively used to hold the unit when it is parked. It is not for use as a stopping brake during its transportation (while being drawn by a vehicle).

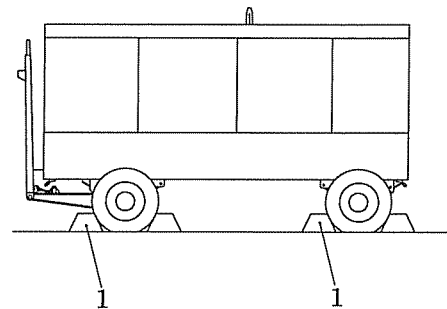

A010189

### 3.4.2 Service valve

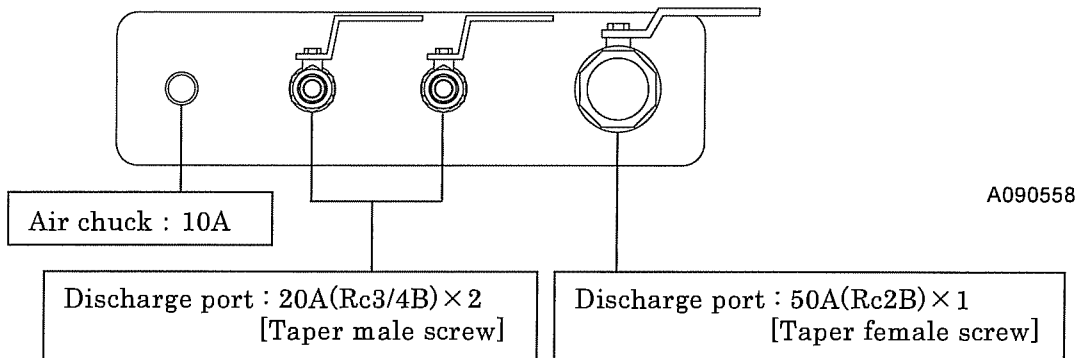



# 4. Operation

## 4.1 Instrument Panel

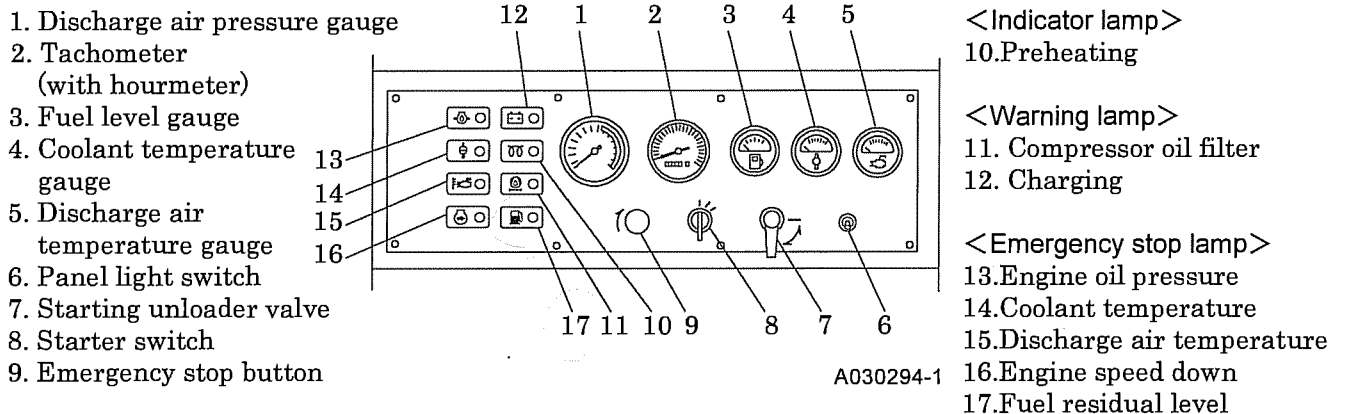

### Indicator lamp

Item	Trouble	Measures	Monitor
Preheating	Press starter switch "ON" and the lamp goes on and after preheating is finished, the lamp will be off.	—	

### Warning lamp

When the lamp goes on, take appropriate measures to recover the situation swiftly.

Item	Trouble	Measures	Monitor
Compressor oil filter	Lamp goes on when the differential pressure increases due to oil filter clogging. The function pressure is than 0.12MPa.	Replace.	
Charging	Lamp goes on when alternator is not charging.	Check wiring. Check alternator.	

### Emergency stop lamp

The compressor stops when the emergency stop lamp goes on.

Be sure to follow the measures shown below before starting the unit again.

Item	Trouble	Measures	Monitor
Engine oil pressure	Lamp goes on when engine oil pressure drops. The function pressure is below 0.15MPa	See "Troubleshooting"	
Coolant temperature	Lamp goes on when coolant temperature reaches 102°C.	See "Troubleshooting"	
Discharge air temperature	Lamp goes on when the air temperature at the outlet of the air-end reaches the set temperature of 115°C. (120°C in case of FACF-150P, 130°C in case of FACG-125P).	See "Troubleshooting"	
Engine speed down	Lamp goes on when engine speed drops below 900min <sup>-1</sup> .	See "Troubleshooting"	
Fuel residual level	When fuel level of fuel tank becomes lower, the lamp goes on.	Add fuel oil.	

## 4. Operation

### 4.2 Door

#### 4.2.1 Open/Close the Door

##### WARNING

- Keep the door closed and locked while running the unit.
- When the door has to be opened, be careful not to touch portions that are rotating or very hot. Careless touch may cause serious injury.



PK0028

- Pull the handle forward to open the door.
- Be sure to close the door tightly so that its latch is firmly caught.

### 4.3 Check before Starting Unit

##### CAUTION

##### *Check before starting the unit*

- Be sure to check the unit before operation. When any abnormality is found, be sure to repair it before restarting the unit.
- Be sure to make daily checks before operation. If the unit is operated without prior check and without noticing its abnormality, such operation could cause seizure of components or may even cause fire.

#### 4.3.1 Check Engine Oil Level

- Unit should be on level before checking oil level.
- When you check oil level after you have once started operation, wait 10 to 20 minutes after stopping engine, before checking the oil level.

(Procedure)

- ① Pull out the engine oil dipstick, and wipe it with a clean cloth.
  - ② Then, re-insert the dipstick fully and pull it out again. If the dipstick shows the oil level between MIN and MAX, it is normal.
  - ③ When the oil level is below its MIN, add engine oil. (See 5.5.1)
- While checking oil level, check also for contamination. If the oil is found dirty, contaminated or should it be changed according to the periodic inspection list, change the oil. (See 5.5.1)

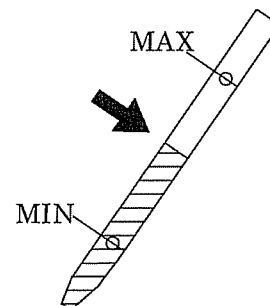

A000166

## 4. Operation

### 4.3.2 Check Coolant Level

#### **CAUTION**

#### *Taking off the Header tank radiator cap*

- Be sure to stop the machine and allow time to cool. Then loosen the radiator cap one notch. After the coolant water is sufficiently cooled and the inner pressure is released, take the cap off. If this procedure is neglected, the inner pressure can blow off the cap. Steam jetting out of the radiator could result in causing scalding. Follow this procedure under all circumstances.



W005

- Check the coolant level in the reserve tank. If it is lower than the limit, open the cap and replenish the coolant. (Level must be kept above MIN mark.)
- If little coolant is left in the reserve tank, replenish the radiator with cooling water. (See 5.5.14)

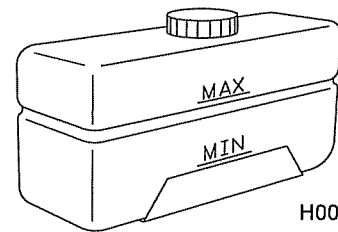

H000474

#### **IMPORTANT**

- Do not continue operation at low coolant level. Air bubble is mixed into radiator, and it causes damage to the radiator.

## 4. Operation

### 4.3.3 Check Compressor Oil Level



**WARNING**

#### *Refilling of compressor oil*

- When you refill the separator receiver tank with compressor oil, stop the engine, and make sure that the pressure gauge indicates 0 MPa and there is no residual pressure in it, and then gradually loosen the oil filler cap for refilling oil.
- Note residual pressure in the receiver tank could force both extremely hot compressed air and oil to jet out and you may be scalded or seriously injured.



W011

- Place the machine on level ground when checking the oil level.
- Check the oil level of the compressor. Correct oil level is between upper and lower limit of the gauge, when the unit stops. If the gauge shows lower than the middle level, replenish oil. (See 5.5.5)

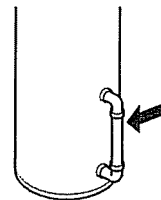

H000037

### 4.3.4 Drain Separator Receiver Tank



**WARNING**

#### *Draining of Separator receiver tank*

- After stopping the engine, confirm that the pressure gauge indicates 0 MPa and there is no residual pressure in it, then open the drain valve gradually to drain the compressor oil.
- Note residual pressure in the receiver tank could force both extremely hot compressed air and oil to jet out and you may be scalded or seriously injured.



W005

- Gradually opening the drain valve "2" fitted under the separator receiver tank "1" as shown in the fig, drain the condensate.
- Be careful not to fully open the valve. Otherwise, much oil may be lost.
- After draining the oil completely, close the drain valve "2" firmly.
- Drain the condensate in container "3", and then dispose of condensate according to the designated regulations.

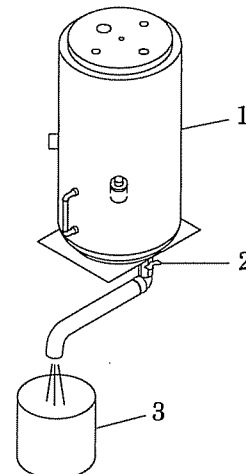

H000489

## 4. Operation

### 4.3.5 Check Fuel level



#### Fire prevention

- Do not, under any circumstance, smoke cigarettes or light matches during fueling.
- Fuel is extremely flammable and dangerous. It therefore, could catch fire should it flame or other sources of ignition be brought near fuel.
- Refuel only after stopping the engine, and never leave an open fuel can near the machine. Do not spill. It could cause a fire. When it is spilt, wipe it up completely.
- Refilling fuel tank should be done in an outdoor well-ventilated place.
- **Do not fill fuel oil up to the cap lever. When fuel tank is filled up to the cap level, fuel oil will be overfilled due to volume expansion caused by rise of ambient temperature. Further, fuel will be possibly spilled from fuel tank due to vibration caused during movement and/or transportation of machine.**



D004

#### IMPORTANT

#### Choose appropriate fuel

- Be sure to use diesel fuel oil for diesel engine use.  
(Using other oil will cause low power or damage to the engine.)
- As for fuel, use diesel fuel oil (having higher than 45 cetane number).
- Use of diesel fuel oil having lower than 45 cetane number will cause inferior function to engine and, what is worse, it will cause serious accident to the engine.
- Check fuel level gauge before operation. Replenish enough fuel to prevent fuel shortage during operation, if the level is low.  
When refueling, fill a fuel tank up to the base of fuel filler port. Never overfill fuel because it may cause fuel leakage.
- Be sure to fasten the fuel tank cap firmly after replenishment. If fuel is spilt, wipe it up completely.

### 4.3.6 Drain Fuel Tank

- Opening the drain valve "2" fitted under the fuel tank "1", drain the condensate from the tank.
- When completely drained, firmly close the drain valve "2".
- Drain the condensate in container "3", and then dispose of condensate according to the designated regulations.

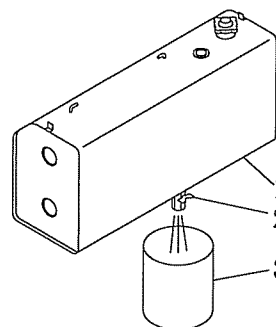

H000490

## 4. Operation

### 4.3.7 Drain Water Sedimenter

Check if the red float "1" in the water sedimenter rises up to the water drain level "2", then drain water if it is near the drain level.

(Draining procedure)

- ① Loosen the drain plug "3" and drain out condensed water inside.
- ② After draining condensed water, close the drain plug "3" without fail.
- ③ Drain the condensate in container, and then dispose of condensate according to the designated regulations.

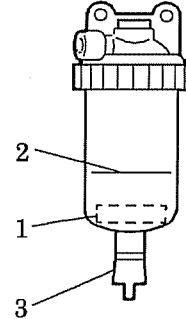

A000064

### 4.3.8 Check V-Belt Tension

#### IMPORTANT

- Too tight belt tension could damage shaft and shorten bearing life. Too loose belt tension may result in damaging belt earlier and machine components due to overheat.

Follow the procedure below to adjust tension of fan belt and V-belt for alternator.

(Procedure)

- ① Adjust the tension by gradually loosening the fastening bolt of the alternator.
- ② Visually check if there are any cracks or tears in the belt.
- ③ Loosen the fastening bolt of the alternator until the play of the belt reaches 10 to 15mm [98N(10kgf)] when pushed by fingers, and adjust it.
- ④ Be careful not to leave any grease or LLC on a belt while changing it. If any such material is left, wipe it off completely.

Depress the middle of the belt with a finger.

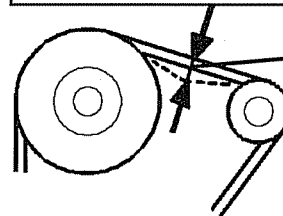

Then check the deflection of the belt and make sure that it shall be 10 to 15mm.

A010181

### 4.3.9 Check Wiring of Each Part

Check each wiring for any loose connection, damage to insulating sheathed portion, disconnection, and short-circuit.

### 4.3.10 Check Piping of Each Part

Check each piping for any loose connection and also check each hose and pipe for any tear and leaks.

## 4. Operation

### 4.4 Unit Operation



***Operation with compressed air supply port opened is prohibited***

- Do not operate the machine with service valves and relief valve open unless air hoses and/or pipes are connected. High-pressurized air blows out and its air pressure could cause injury to the people nearby.
- When the machine has to be unavoidably temporarily operated with its port open, be sure to mount a silencer to reduce noise and wear protective materials such as earplugs to prevent damage to hearing.

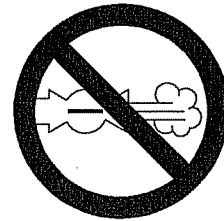

D003

#### ***Quick Glow System***

- Turn the starter switch to the "RUN" position, and the preheating will be completed in several seconds and the preheating lamp will go out. Then, turn the Starter Switch to the Start position to start up the engine.
- When the engine is already warm, the preheating operation is automatically omitted. Even though the preheating lamp lights up momentarily, ignore the lamp status, and start up the engine.

## 4. Operation

### 4.4.1 Procedure to Start the Unit

#### IMPORTANT

——— *Be sure to warm-up* ———

- Be sure to let unit warm-up after starting for smooth operation of the engine and the compressor. Do not operate the engine at full load immediately after it starts up. This will shorten the equipment life.
- During the warm-up operation, examine the different parts of the equipment for any looseness, leakage of water, oil, fuel, and other irregularities.
- Also, make sure that warning lamps are off.

(Procedure)

- ① Close fully service valves “1” .
  - ② Set the starting unloader valve “2” to “START” position.
  - ③ Turn the starter switch “3” to “RUN” position, and the preheating lamp “4” goes on.
  - ④ As soon as the preheating lamp “4” has gone out, turn the starter switch “3” fully clockwise to start up the engine.
  - ⑤ Once the engine has started up, leave it running to warm-up for 5 minutes. The discharge air pressure gauge “5” in this condition ranges from 0.46 to 0.7 MPa.  
[FACF-150P 0.39 to 1.05 MPa]  
[FACG-125P 0.39 to 1.27 MPa]
  - ⑥ After warm-up of the unit, put the starting unloader valve “2” back to its “RUN” position, and open the service valve The unit is now ready to operate.
- Be sure to turn the starting unloader valve “2” to “RUN” position prior to work. The discharge pressure does not increase as long as the starting unloader valve “2” stays at “START” position.

It is normal when the pressure gauge indicates the pressure between 0.46MPa and 0.7MPa.  
[FACF-150P 0.39 to 1.05 MPa]  
[FACG-125P 0.39 to 1.27 MPa]

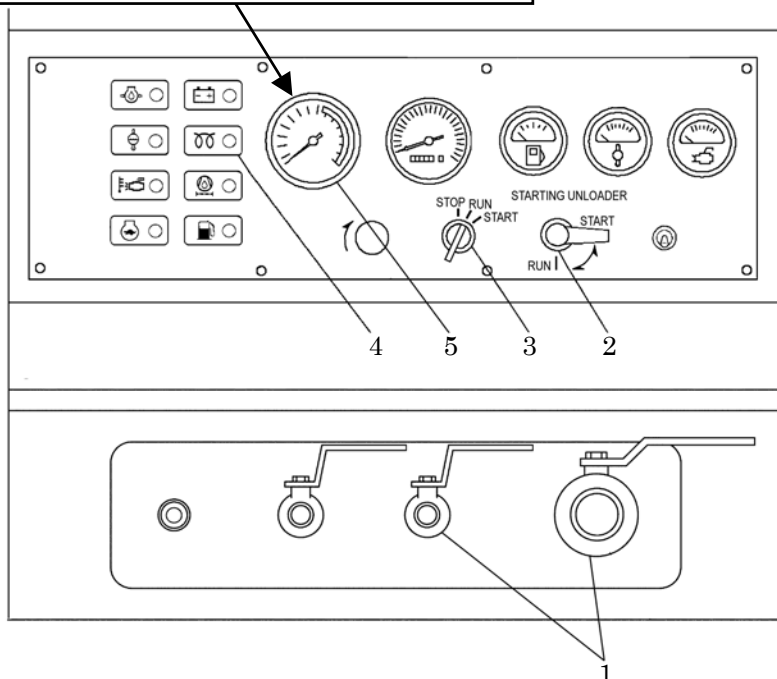

A030298-1



## 4. Operation

### 4.4.2 Operating Procedures when Engine Fails to Start up on First Attempt

- When the engine fails to start up even after performing the startup procedures ① to ④, do not keep the starter running, but set the starter switch back to "STOP" and wait about 30 seconds. Then, repeat the startup procedure once again.
- If the repeated procedure does not allow the engine to run, the following causes are suspected. Therefore, check the following:
  - No fuel
  - Clogging of fuel filter
  - Clogging of filter inside the fuel air bleeding electromagnetic pump
  - Discharge of battery (Low cranking speed)

### 4.4.3 Fuel Line Air Bleeding Device

If the unit runs out of fuel, the electromagnetic pump attached to the unit will automatically bleed air out of the fuel system. (After draining sediment from water sedimentor or changing fuel filter with a new one, bleed the air in the same procedure as below.)

(Procedure)

- ① Supply fuel.
- ② Turning the key of starter switch "1" to "Operation" position, the solenoid valve starts to bleed air in the fuel piping system automatically.
- ③ Air bleeding will be completed about 20 to 30 seconds.
- ④ Start the machine following the starting procedures mentioned in 4.4.1. If starting fails one time, repeat the abovementioned procedures.

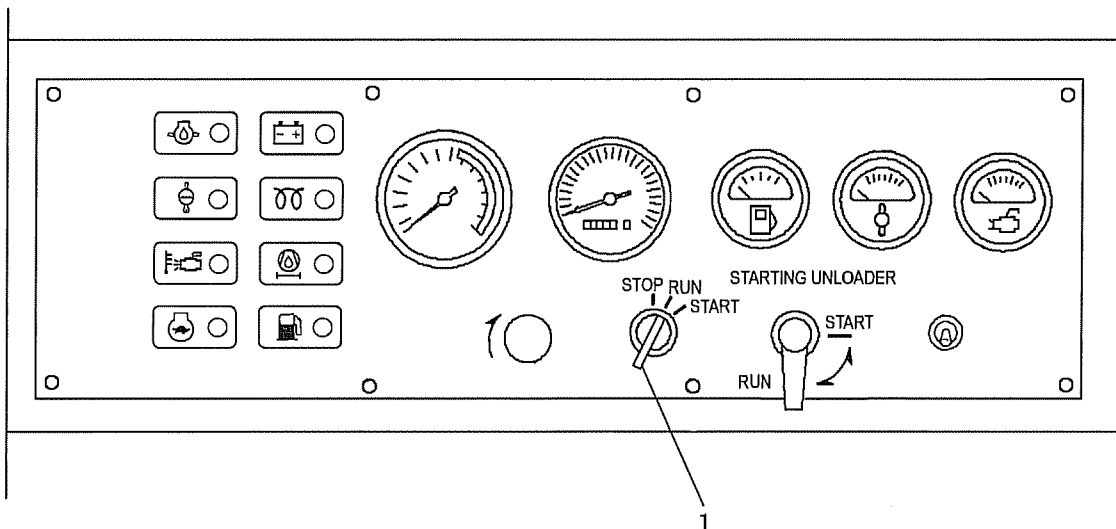

A030299-1

# 4. Operation

## 4.4.4 How to Start the Unit at Low Temperature

### IMPORTANT

Operation under Cold Weather Conditions below  $-5^{\circ}\text{C}$

- Use SAE10W-30 (CD class) for the engine oil.
- Use LLC (antifreeze). Use correct amount to provide freeze protection, according to the ambient temperature.
- Battery should always be kept fully charged.

When it is difficult to start engine in cold weather, take the following measures.

(Procedure)

- ① Close all the service valves "1" and set the starting unloader valve "2" to the starting position.
- ② Fully open the relief valve "3" just in front of a separator receiver tank.
- ③ With emergency stop button "4" pressed in, turn the starter switch "5" to the starting position and perform cranking 4 to 5 seconds two times.
- ④ Reset the emergency stop button "4" .
- ⑤ Perform usual starting operation. When the engine starts, gradually close a relief valve "3" , watching engine revolution rise. In the state after the valve is fully closed, perform warming-up operation.

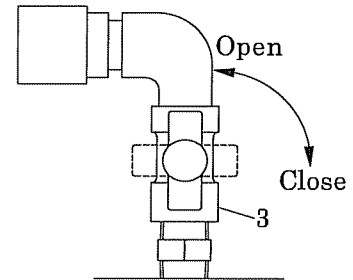

H000475

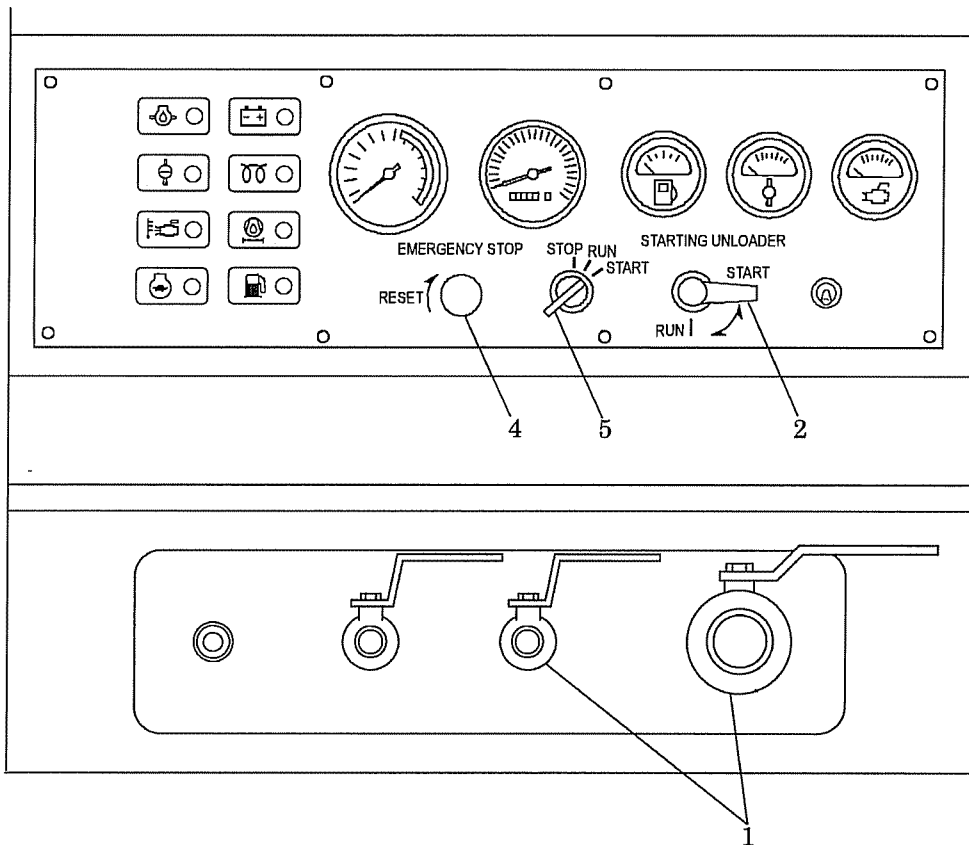

A030300-1









## 4. Operation

### 4.4.5 Gauge Indication while Operating

#### IMPORTANT

- Minimum discharge air pressure is 0.46 MPa, FACF-150P, FACG-125P 0.39 MPa during operation
- Continuing equipment operation at a lower pressure than the above pressure may cause overheating, since it affects the separation of lubricating oil inside the oil separator and reduces the oil flow to the compressor air-end, resulting in temperature rise.
- Make sure that RPM is higher than  $1,100\text{min}^{-1}$  at no load (or low load) operation. Long continuous operation at the lower speed than  $1,100\text{min}^{-1}$  could cause damage to each part by vibration. When the speed becomes lower than  $1,100\text{min}^{-1}$ , stop the machine soon.

- Be sure to check at times to see if gauges or each component of the unit are properly working, or if there is any air-leak, oil-leak, water-leak or fuel-leak etc.
- During normal operation, each indication of instruments is shown in the table below. Refer to the table for daily checks.
- The above table gives standard values. They may vary slightly depending on the operating conditions and other factors.

Protection device	Emergency stop Lamp					Warning Lamp		Indicator lamp
	Engine oil pressure	Coolant temp.	Discharge air temp.	Engine speed down	Fuel residual level	Compressor oil filter	Charging	Preheating
Monitor								
Starting switch set to "RUN" position	※1 ● OFF	● OFF	● OFF	● OFF	● OFF	● OFF	● ON	※2 ● OFF
In Operation	— ● — OFF							

Note: ※1 After turning the starter switch to "RUN" position, lamp goes on 20 seconds later.  
 ※2 Lamp goes off after preheating completed.

In Operation	Model	Discharge air pressure
		At Unload
	FACF-150P	1.05~1.25 MPa
	FACG-125P	1.27~1.55 MPa
At Full Load	FAC-185P	0.46~0.7 MPa
	FACF-150P	0.39~1.05 MPa
	FACG-125P	0.39~1.27 MPa

### 4.4.6 Panel light

- The instruments are provided with transmission type illuminators. Switch "ON" the panel light so that they may light on.
- When illumination is not necessary, turn "OFF" the light. (If the machine is always operated with the lamp switched "ON", the lamp life can be shortened.)

## 4. Operation

### 4.4.7 Performance Check of Safety Valve

#### WARNING

- Keep face or hand away from the discharging outlet of safety valve. It is very dangerous because high-pressure compressed air jets out.

#### IMPORTANT

#### CAUTION – Wear safety glasses

- Make sure to check the safety valve “1” performance once a day.
- Close the service valves completely and pull the test ring “2” to check the performance. It is performing normally when the compressed air jets out with turning by slight force at a discharge pressure between the following pressures.
- FAC-185P ..... 0.7 to 0.9 MPa
- FACF-150P ..... 1.05 to 1.25 MPa
- FACG-125P ..... 1.27 to 1.55 MPa
- The safety valve is set at the following pressure.
- FAC-185P ..... 0.9MPa
- FACF-150P ..... 1.25MPa
- FACG-125P ..... 1.55MPa

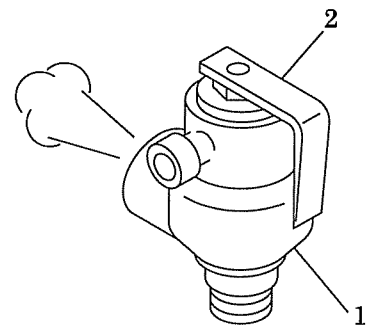

H000476

### 4.4.8 Check Clogging in Oil Separator

When the differential pressure gauge of oil separator shows red range, replace the oil separator.  
(See 5.5.17)

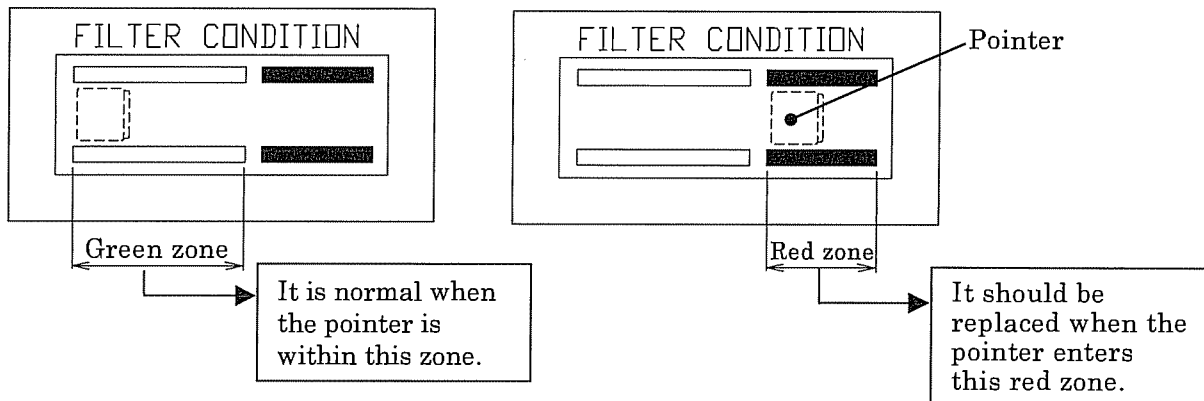

H000477

## 4.5 Stopping Procedures

- ① Close the service valve completely and operate the machine about 5 minutes, until it cools down.
  - ② Turn the starter switch to “STOP” position to stop the engine.
  - ③ Remove the key from the compressor every time when you stop the engine. Keep the key and be careful not to lose it.
- Unless all the service valves are fully closed upon stopping operation, the compressed air will be sent in reverse direction in the hoses (pipes) connected to air tools and relieved to atmosphere continuously through the auto-relief valve. Further, when re-starting operation next time, compressed air will be jetted out through service valves.

## 5. Periodic Inspection/Maintenance

### 5.1 Important Items at Periodic Inspection and Maintenance or after Maintenance

The following table shows the inspection and maintenance intervals under normal operation conditions. When used or operated under hard environmental conditions, it is impossible to warrant the unit even if the above conditions are performed according to the intervals listed in the above table.



**WARNING**

**Hang a "Now Checking and under Maintenance" tag**

- Remove the starter key from the starter switch before starting inspection, and hang up a "Now Checking and under Maintenance" tag where it can be easily seen. The checker must keep the key during checking and maintenance.
- Remove the negative (-) side cable from the battery. If the above procedure is neglected, and another person starts operating the machine during check or maintenance, it could cause serious injury.
- Use tools appropriate for the inspection and maintenance. Any makeshift or improper tools could cause unexpectedly injury by their slippage.

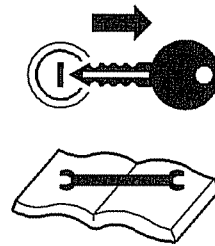

SY001

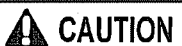

**CAUTION**

**Prevention of oil separator from catching fire**

- Be sure to perform oil change basically according to the specified interval. But if such oil is found much more contaminated before the interval, change the oil even before the specified period comes. In doing so, replace the oil completely and use our recommended oil.
- Be sure to perform following periodic inspection and maintenance:
  1. Check and change compressor oil
  2. Change oil separator
- Never mix the oil of different brands, or the mixed oil may deteriorate the oil quality.

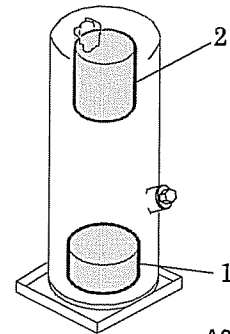

A000174

## 5. Periodic Inspection/Maintenance

### IMPORTANT

#### Precautions for check and maintenance

- Be sure to use recommended fuel, oil, grease, and antifreeze.
- Do not disassemble or adjust engine, compressor or part(s) for which inspection or maintenance is not referred to in this manual.
- Use genuine parts for replacement.
- Any breakdown, caused by using unapproved parts or by wrong handling, will be out of the scope of "WARRANTY".
- Keep the electrical components away from water or steam.
- Waste from machines contains harmful material. Do not dispose of such harmful fluids to the ground, rivers, lakes or ponds, and sea. It contaminates the environment.
- When draining waste fluid from machines, use leakproof containers to hold such fluids from machine.
- Be sure to follow the designated regulations when disposing of oil, fuel, coolant, filters, battery and other harmful things.

### 5.2 Daily Inspection and Operation Log

- Be sure to carry out daily inspection every morning before operation. See Chapter 4 "Operation" of the manual for the details of inspection.
- Pay attention to and carefully observe the following points during daily operation or inspection and maintenance work. If any trouble or abnormality is found, immediately investigate its cause and make repairs. If the cause is unknown or not traceable, or if the trouble involves a part or component not described in the manual, ask your nearest dealer for information.

- (a) Controls and instruments function properly.
- (b) Quantity and any leak of water, fuel, and oil or any contamination should be checked.
- (c) Appearance, abnormal noise or excessive heat should be checked.
- (d) Loose bolt or nut should be checked.
- (e) Any damage, wear or shortage of machine components and parts should be checked.
- (f) Performance of each part or component should be proper.

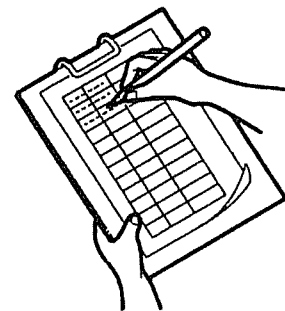

TR0049

- Keep the operation log to record constant inspection of each component, so that trouble of the unit can be easily discovered and preventive measures can be taken.  
It is very useful to record information such as discharge pressure, oil level, as well as running hour, maintenance items and replenishment of lubricant on a daily maintenance log.

## 5. Periodic Inspection/Maintenance

### 5.3 Periodic Inspection List

Such items marked ○ shall be carried out by customers.

For the following items or clauses marked ●, contact us directly or our distributors because they require expert technical knowledge on them.

(Unit:Hour)

Maintenance	Daily	250	300	500	1,000	2,000	3,000	6,000	12,000	Page
Check compressor oil level.	○									4-4
Drain separator receiver tank.	○									4-4
Check looseness in pipe connecting part, and wear and tear of pipe.	○									4-6
Check oil, water, fuel and air leak.	○									4-10
Check performance of gauge and indication lamps.	○									4-10
Performance check of safety valve.	○									4-12
Change compressor oil.		○ (FACG-125P)	○ First time	○	※1○ (FACG-125P)					5-8
Change compressor oil filter.		○ (FACG-125P)	○ First time	○						5-9
Clean strainer in the scavenging orifice.				○						5-9
Change air filter element.		○ (Clean)		○ (Change)						5-10
Clean outside of the oil cooler.					○					5-11
Change speed regulator diaphragm.					☆●					
Change unloader regulator diaphragm.							★●			
Change oil separator.						○				5-13
Change nylon tubes.						●				
Change pressure regulator diaphragm.					☆●					
Change rubber hoses.							★●			
Check diaphragm of auto-relief valve.							★●			
Clean butterfly valve (unloader)							●			
Change diaphragm of vacuum-relief valve (FACF-150P, FACG-125P only)							★●			
Change o-ring of vacuum-relief valve (FACF-150P, FACG-125P only)							★●			
Change o-ring of pressure control valve (FACF-150P, FACG-125P only)							★●			
Replace the parts of pressure control valve (spare kit).								●		
Change rubber coupling.									●	
Change oil seal and bearing									●	

※1 Change time when used MOBIL RARUS SHC 1025

The items or parts marked ☆ should be replaced every two years even if they are not in disorder within their periodical maintenance interval because their materials will change or become degraded as time passes.

Also for the same reason, the parts marked ★ should be replaced every three years.

## 5. Periodic Inspection/Maintenance

☉ Refer to engine operation manual for inspection and maintenance of an engine.

(Unit:Hour)

	Maintenance	Daily	50	250	500	1,000	2,000	3,000	6,000	Page
Engine	Drain fuel level. (Including sedimenter)	○								4-5
	Check fuel level	○								4-5
	Check engine oil level.	○								4-2
	Check coolant level.	○								4-3
	Check looseness in pipe connectors, terminals and tear in wiring.	○								4-6
	Check V-belt tension.	○								4-6
	Change engine oil.		○ First time			○				5-6
	Change engine oil filter.		○ First time			○				5-7
	Check battery electrolyte.				○					5-7
	Clean and change air-filter element.				○ (Clean)		○ (Change)			5-7
	Clean and change filter inside the fuel air bleeding electromagnetic pump.					○				5-11
	Clean strainer of fuel air-bleeding electromagnetic pump.					○				5-11
	Change fuel filter.					○				5-10
	Checking for looseness of fixing belts of heat insulating material used for exhaust flexible pipe.					○				5-10
	Clean the strainer provided inside the engine feed pump.						○			5-13
	Change coolant.						☆○			5-12
	Clean outside of radiator.						○			5-11
	Change fuel hose.							★●		5-13
	Clean inside of radiator.						●			
	Clean inside of fuel tank.							●		
Change radiator hoses.								★●		
Change wiring harness.									●	

The items or parts marked ☆ should be replaced every two years even if they are not in disorder within their periodical maintenance interval because their materials will change or become degraded as time passes.

Also for the same reason, the parts marked ★ should be replaced every three years.

(Unit:Hour)

	Maintenance	Daily	250	300	500	1,000	2,000	3,000	6,000	Page
Undercarriage	Supply grease to trailer hub bearing.					●				5-14
	Supply grease to each part of trailer.					○				5-13
	Check and confirm that the nuts with which tires are fixed are properly tightened.			○ Every 3 months						5-14



## 5. Periodic Inspection/Maintenance

---

### 5.4 Periodic Replacement of Parts

#### 5.4.1 Filters

Part Name		Part Number	Quantity
Engine oil filter		Hino motors 15607-2190	1
Compressor oil filter		37438 05400	1
Air filter element (compressor)		32143 15200 (inner cyl.) "1"	1
		32143 15300 (outer cyl.) "2"	1
Air filter element (engine)		32143 14800 (inner cyl.) "3"	1
		32143 12800 (outer cyl.) "4"	1
Fuel filter		Hino motors 23401-1341	1
Oil separator	Separator "1"	34220 12501	1
	Gasket "2"	34235 06700	2
Electromagnetic pump filter		43541 00100	1
Auto-drain valve		34520 00200	1
Fuel feed pump gasket		43531 00700	3

# 5. Periodic Inspection/Maintenance

## 5.5 Maintenance

### 5.5.1 Change Engine Oil

- At 50 hours for the first change and at every 500 hours thereafter



**Caution in filling or discharging engine oil**

- After stopping the engine, wait for 10 to 20 minutes until the engine oil cools off. Then check the level of the engine oil, or refill or drain the oil.
- Engine oil is very hot and highly pressurized during or just after the operation. Hot oil could blow out of the tank and can cause scalding.



W005



**— How to choose engine oil —**

- Viscosity of engine oil greatly affects startability, performance, oil consumption of the engine, as well as wear of the moving parts.
- Choose appropriate oil based upon the table below according to the outside air temperature.

Ambient temperature range and oil viscosity (SAE)

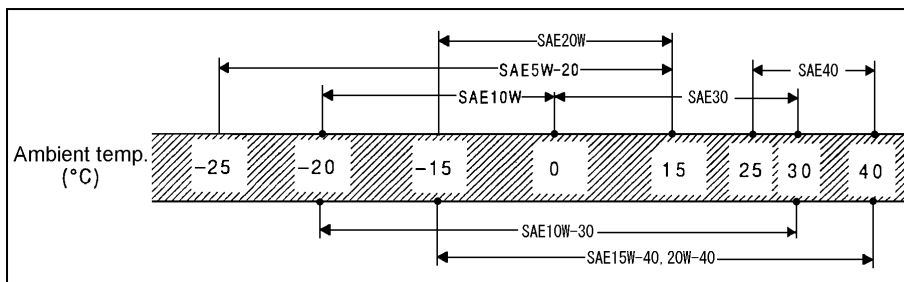

A100293E

- Use engine oil recommended by us.

Classification	API service classification CD class or higher
Viscosity	SAE10W-30

- Be sure to use CD class engine oil or superior class. (Using engine oil with poor quality may shorten the life of the engine).
- Follow the designated regulations to dispose of engine oil.

(Procedure)

- ① Loosen the drain valve “2” located outside of the frame to drain out the used oil.
- ② When the oil is completely drained, close the drain valve “2” firmly and refill new engine oil through the engine oil filler “1” .

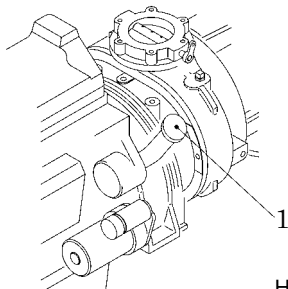

H000493

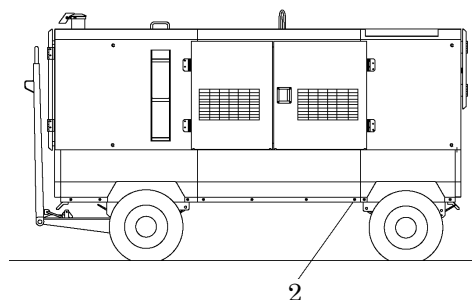

H000495

## 5. Periodic Inspection/Maintenance

### 5.5.2 Change Engine Oil Filter

- At 50 hours for the first change and at every 500 hours thereafter

(Procedure)

- ① Remove the cartridge "1", using a filter wrench.
- ② Screw in the new cartridge "2" with the packing coated slightly with oil. (For replacement parts, refer to 5.4)
- ③ After the packing touches the sealing face, further tighten it by turning it 3/4 - 1 time with the filter wrench.
- ④ After installing the oil filter, check it for any leak during operation.

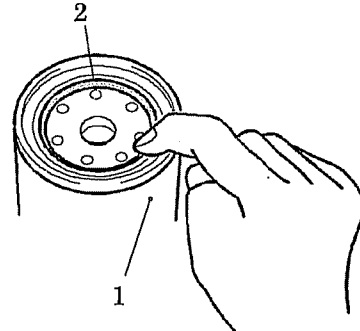

H000049

### 5.5.3 Check Battery electrolyte

If there seems to be a problem in starting an engine due to a flat battery, carry out the checks by following the procedures below:

#### 1. Enclosed type battery:

Check the indicator on top surface of the battery.

If the indicator shows that charge is needed, recharge the battery immediately.

#### 2. Ordinary type battery:

Measure specific gravity of battery electrolyte, and if it shows below 1.24, recharge the battery immediately.

Refer to 6.1. for method of specific gravity measurement and recharging the battery.

### 5.5.4 Clean and change Air Filter Element

#### IMPORTANT

— *Cleaning of Air Filter Element should be perfectly performed* —

- Clogged or cracked or pitted element could allow entrance of dust into engine and compressor to cause earlier wear of moving parts. Periodical inspection and cleaning of element should be performed to maintain life of compressor and engine long.

- Remove both external shell "2" and "4", and clean them.
- Replace both internal shell "1" and "3" once in the proportion of replacing external ones four times. The internal ones can never be reused even after they are cleaned.
- When it is found that they cannot be repaired even after being cleaned, replace the elements. (See 5.5.9)

(For compressor)

(For engine)

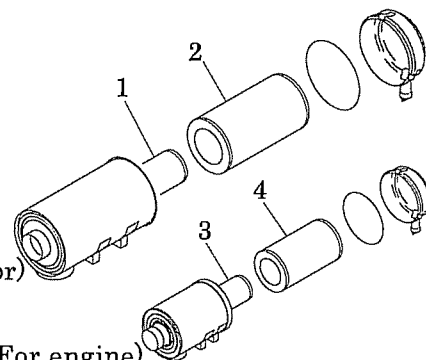

A020263

## 5. Periodic Inspection/Maintenance

### 5.5.5 Change Compressor Oil



**WARNING**

*Refilling of compressor oil*

- When you refill the separator receiver tank with compressor oil, stop the engine, and make sure that the pressure gauge indicates 0 MPa (0 kgf/cm<sup>2</sup>) and there is no residual pressure in it, and then gradually loosen the oil filler cap for refilling oil.
- Note residual pressure in the receiver tank could force both extremely hot compressed air and oil to jet out and you may be scalded or seriously injured.
- Be sure to use recommended oil listed below.

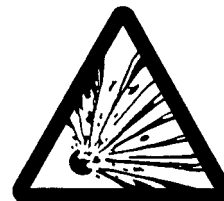

W011

**IMPORTANT**

— *Do not mix compressor oil* —

- Be sure to use recommended oil listed below.
- Viscosity of the oil varies depending on the temperature and other environmental conditions.
- Select one from the recommended oil listed below.

**Maker and Brand of Recommended Oil**

Temperature	Brand	Maker
-15 to 40°C	MOBIL RARUS 424 (FAC-185P, FACF-150P)	MOBIL
5 to 40°C	MOBIL RARUS 425 (FACG-125P)	
-15 to 40°C	MOBIL RARUS SHC 1025 (FACG-125P)	
-15 to 40°C	SHELL CORENA OIL RS32 (FAC-185P, FACF-150P)	SHELL
-15 to 40°C	FAIRCOLD RA32 (FAC-185P, FACF-150P)	NIPPON OIL CO.

- Even continuous oil replenishment cannot improve its deteriorated condition. Be sure to change the oil completely at every scheduled interval.
- Do not mix it with other brand oil, or it will cause poor performance and shorten the life of the compressor oil. (But fresh compressor oil could accept a mixture of small amount of different brands.)
- Running the unit with old and deteriorated compressor oil will cause damage to bearings, or serious accident like ignition in a separator receiver tank. Be sure to change the oil completely at every scheduled interval.
- Follow the designated regulations to dispose of compressor oil.

## 5. Periodic Inspection/Maintenance

(Procedures)

- ① Remove the oil filler cap "2" of separator receiver tank "1".
- ② Open drain valve "3" to discharge waste oil from the tank.
- ③ In case of replacement, completely discharge all the oil left in the compressor body, separator receiver tank "1", pipes and oil cooler. If wasted oil is left in the unit, this residual oil will greatly shorten the life of the newly replenished oil.
- ④ Be sure to close drain valve "3" after the wasted oil is completely discharged.
- ⑤ Fill the designated quantity of new oil into the oil filler port.
- ⑥ After oiling, tighten the cap "2" in its place while paying attention not to let dust get in the tank.
- ⑦ Start the engine for a short while, then replenish the oil to fill shortage. Repeat this procedure for 2 to 3 times to check if the oil level has reached its appropriate point. Be careful not to overfill the oil.

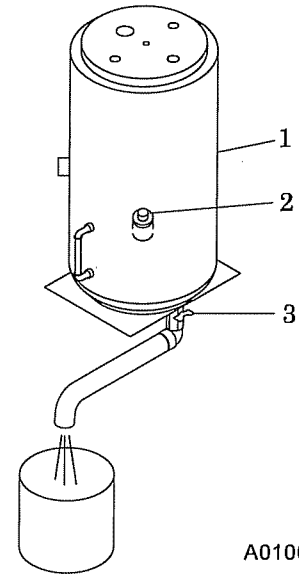

### 5.5.6 Change Compressor Oil Filter

- At 300 hours for the first change and every 500 hours thereafter

**IMPORTANT**

Use our genuine oil filter

- Poor quality oil filters do not trap dust sufficiently and will cause damage to the bearings in a short period.

(Procedure)

- ① Use a filter wrench to remove the cartridge "1".
- ② Spread thin film of oil on a packing "2" of a new cartridge "1" and screw it in. (For replacement parts, refer to 5.4)
- ③ After packing touches the sealing face, tighten it 3/4 or one time turn, using filter wrench.
- ④ After installing oil filter, be sure to check for oil leak during the operation.

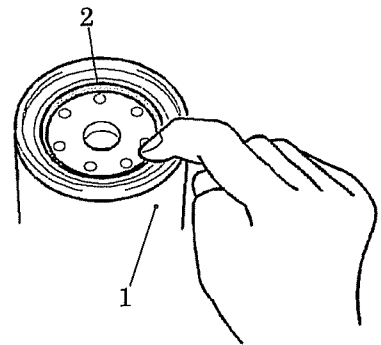

### 5.5.7 Clean Strainer in the Scavenging Orifice

Wash the strainer "1" with diesel fuel, and blow off the "dust" with air.

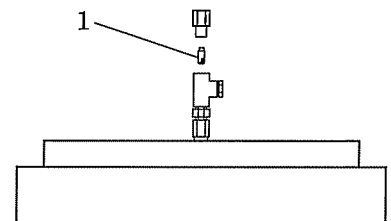

## 5. Periodic Inspection/Maintenance

### 5.5.8 Checking for looseness of fixing belts of heat insulating material used for exhaust flexible pipe.

- When any looseness on fixing belt "3" wound around exhaust flexible pipe "1" is found, retighten it.
- When any damage on heat insulating material "2" is found, it is necessary that it should be replaced. Please contact our distributor or us directly.

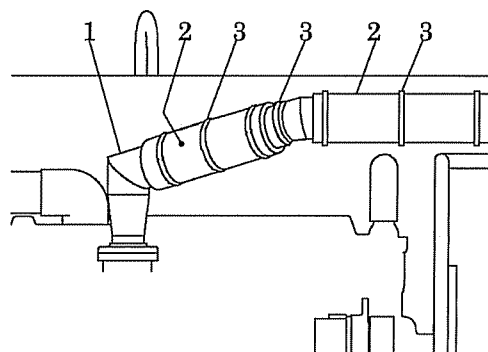

A090645

### 5.5.9 Change Air Filter Element

**IMPORTANT**

— Use our genuine part —

- Air filter is an important part which is crucial to machine's performance and life. Be sure to use genuine parts.
- Even before 500 hours of use, if it is used under harsh conditions, remove the element "1", "2", "3", "4" check and clean it. If it is found difficult to restore it, change it a little earlier. (For replacement parts, refer to 5.4.)

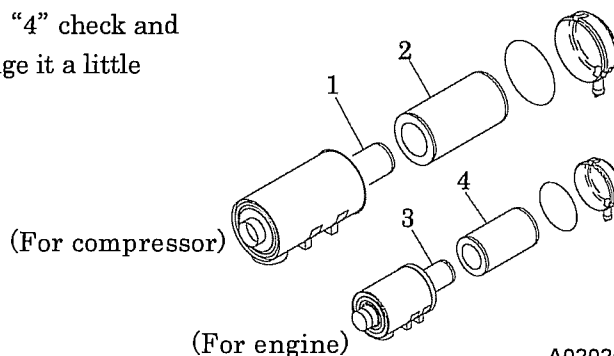

A020263

### 5.5.10 Change Fuel Filter

(Procedure)

- ① Remove the cartridge "1", using a filter wrench.
- ② Spread thin film of oil on a packing "2" of a new cartridge "1" and screw it in. (For replacement parts, refer to 5.4)
- ③ After packing touches the sealing face, tighten it by turning 2/3 times using a filter wrench.
- ④ After installing a fuel filter, be sure to check for oil leak during operation.
- ⑤ Bleed air out of fuel line. (Refer to 4.4.3)

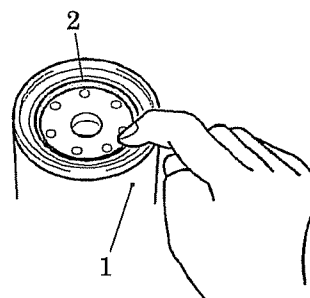

H000049

## 5. Periodic Inspection/Maintenance

### 5.5.11 Clean and Change filter inside the fuel air bleeding electromagnetic pump

(Procedure)

- ① After closing valve “2” , remove the filter “1” and wash it with diesel fuel oil.
- ② After washing of the filter is finished, be sure to close the valve “2” without fail.
- This filter can be washed twice for use. It should be replaced from third time washing.  
(For replacement parts, refer to 5.4)

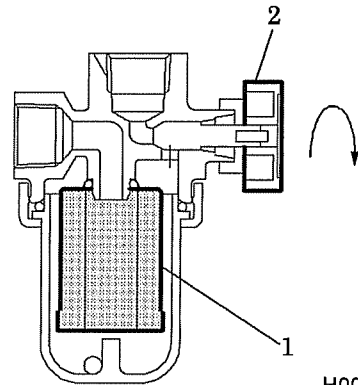

H000164

### 5.5.12 Clean strainer of fuel air-bleeding electromagnetic pump

- Disconnect the fuel line connecting hose and take out the strainer “1” . After washing it with diesel fuel oil, clean it by air blow

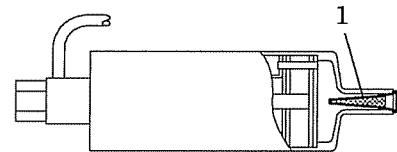

H000165

### 5.5.13 Clean outside of the Radiator·Oil Cooler

- When the fin tubes “1” of a radiator, an oil cooler are clogged with dust or other foreign materials, the heat exchange efficiency drops and this will raise coolant temperature and discharge air temperature. These tubes and fins should be cleaned depending on the state of clogged tubes “1” even before 1000 hours maintenance schedule.
- Do not use a high pressure washer to protect fin tubes “1” from being damaged.

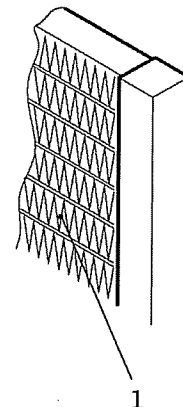

H000054

## 5. Periodic Inspection/Maintenance

### 5.5.14 Change Coolant



#### *Taking off the radiator cap (header tank)*

- Be sure to stop the machine and allow time to cool. Then loosen the radiator cap (header tank) one notch. After the coolant water is sufficiently cooled and the inner pressure is released, take the cap off. If this procedure is neglected, the inner pressure can blow off the cap. Steam jetting out of the radiator could result in causing scalding. Follow this procedure under all circumstances.



W005



#### *How to handle LLC (Antifreeze)*

- LLC (Antifreeze) is a toxic material.
- When a person has drunk LLC (Antifreeze) by accident, make him vomit and see a doctor immediately.
- When a person gets LLC (Antifreeze) in his eyes, wash the eyes with clean running water and make him see a doctor immediately.
- When LLC (Antifreeze) is stored, put it in a container with an indication saying "LLC (Antifreeze) inside" and seal it up, then keep it in a place away from children.
- Beware of flames.

#### **IMPORTANT**

#### *Quality of coolant and antifreeze*

- Use soft water of good quality such as tap water for coolant.
- When water with dirt, sand, and/or dust contained, or hard water such as well water (ground water) is used, this will cause deposits inside radiator or on cylinder head, and will cause engine overheat due to poor flow of coolant.
- When replacing coolant, be sure to install a coolant filter and add coolant.
- When the unit is used in a cold region and possible freezing is expected, it is recommended to use LLC (Antifreeze) for the coolant.
- Adjust mixing ratio of LLC (Antifreeze) with water according to the temperature.
- Use LLC (Antifreeze) within the range of its mixing ratio between 30 and 60%.
- If LLC (Antifreeze) in the water exceeds more than 60%, it may decrease its antifreezing effect. (Upon delivery from the works, LLC density is 35%)
- Follow the designated regulations to dispose of LLC (Antifreeze).

(Procedure)

- ① To drain coolant, remove cap "1" of header tank on radiator top and open the drain valve to drain it.
- ② Also be sure to drain engine by loosening the drain plug "3" without fail.
- ③ After completing drainage, close the drain valve "2" and drain plug "3" and then supply coolant through the filler port of the header tank.
- ④ After coolant is filled up, run unit at unload condition for 2 or 3 minutes and stop it. Then check coolant level. When the level is low, replenish it.

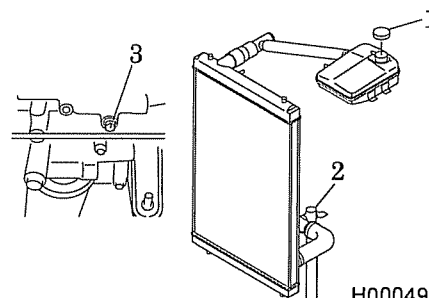

H000491



## 5. Periodic Inspection/Maintenance

### 5.5.15 Supply grease to trailer spring pin

- Supply grease through grease nipples positioned at the bottom.

Grease: Chassis grease

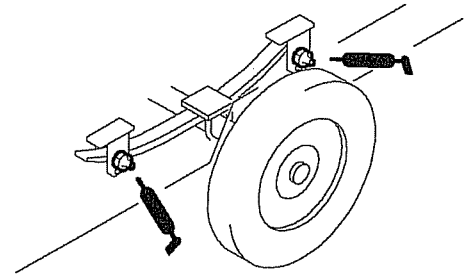

TR0260B

### 5.5.16 Change Oil Separator

- If even before scheduled interval of 2000 hours operation, consumption of compressor oil is unusually high, and the differential pressure gauge of the oil separator reaches Red range, change the oil separator. (Refer to 4.4.8) But note that the differential pressure gauge shows correct indication only in full load operation and minimum pressure.
- When replacing oil separator "1", be sure to replace gasket "2" too. (For part numbers, refer to 5.4.)
- If you have any problem, please contact your nearest distributor.

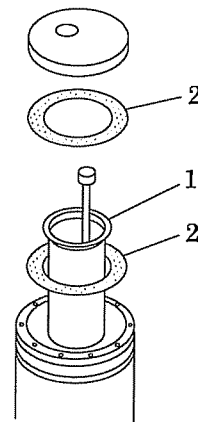

H000483

### 5.5.17 Change Fuel hose

- When any crack or wear is found on the hoses, change it even before the scheduled time.
- Replacement of the hoses requires expert technical knowledge. So contact directly us or distributor.

### 5.5.18 Clean the strainer provided inside the engine feed pump

- Periodically remove the strainer "1" inside the feed pump, and clean it.
- Remove the strainer "1" by loosening the joint bolt and clean it with diesel fuel oil, and also using high air pressure blow. At this time be sure to replace gasket. (For part numbers, refer to 5.4.) Then after finishing all cleaning jobs, install it again in reverse steps.

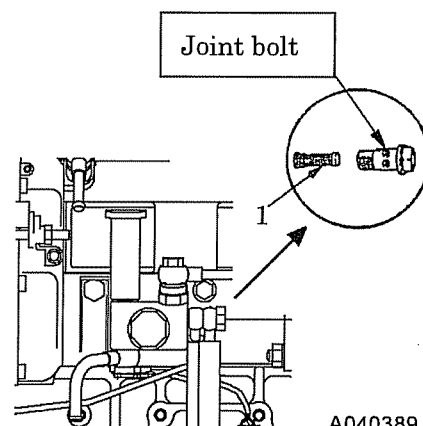

A040389

## 5. Periodic Inspection/Maintenance

### 5.5.19 Supply grease to trailer hub bearing

- Call your nearest dealer for replenishing grease to the trailer hub bearing.

**Grease: Chassis grease**

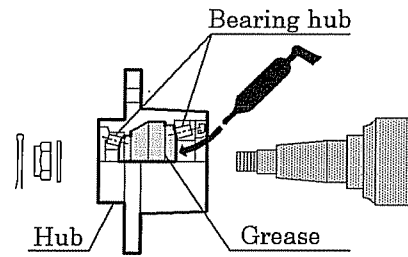

TR0260E

### 5.5.20 Check and confirm that the nuts with which tires are fixed are properly tightened.

- Check and confirm once every three months that hub nuts with which tires are fixed are not loosened. (16 points)
- If it is found that specified tightening torque of clamped bolts drops to a lesser value, retighten them to correct specified value. (Standard pressure for a tire is at 450kPa.)

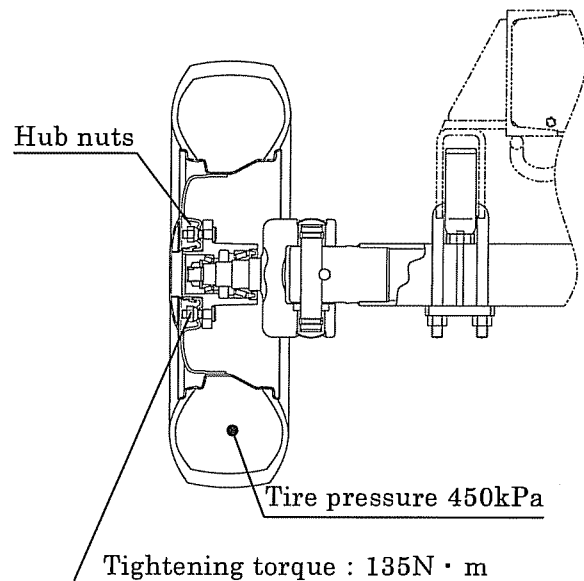

A100248

## 5.6 Inspection on Separator Receiver Tank

**IMPORTANT**

### *Periodic inspection of separator receiver tank*

- Be sure to carry out the following cleaning and inspection of the separator receiver tank at least once every year.  
(Place to check)
  - (1) Any damage found on the tank.
  - (2) Any excessive wear found to fastening bolts on the cover.
  - (3) Any damage found to pipes and valves etc.

## 6. Maintenance/Adjustment

### 6.1 Maintenance of Battery

#### WARNING

#### Handling battery

- Keep flames away from battery.
- Battery may generate hydrogen gas and may explode.
- Therefore, recharging should be done at a well-ventilated place.
- Do not spark near the battery nor light a match, nor bring lit cigarette and match close to the battery.
- Do not check the battery by short-circuiting the positive and negative terminals with a metallic piece.
- Never operate the machine nor charge the batteries with the battery liquid level being kept lower than the "LOWER" level. Continuing operation at this lower level will cause deterioration of such parts as pole plates etc., and also it may cause explosion as well as reduction of battery life. Add distilled water so that the liquid level may reach the middle level between the "UPPER" and "LOWER" level without any delay.
- Do not charge the frozen battery. Otherwise it may explode. If the battery is frozen, warm it up until the battery temperature becomes 16°C to 30°C.
- Battery electrolyte is dilute sulfuric acid. In case of mishandling, it could cause skin burning.
- When you deal with a battery, please be sure to wear protection implements, such as protection glasses and a glove.
- When such battery electrolyte contacts your clothes or skin, wash it away with large amount of water immediately.
- If the battery electrolyte gets into your eyes, wash it away immediately with plenty of water and see a doctor at once, because it is feared that eyesight might be lost.
- Dispose of battery, observing local regulations.



D004

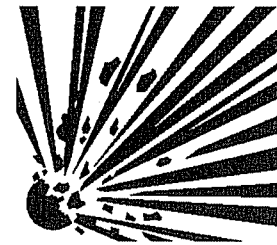

W010



TR0093

#### CAUTION

#### *Do not connect the cable reversely*

- If a booster cable has to be used or when cables are connected at battery replacement, be careful not to connect (+) and (-) terminals backwards. Such a wrong-connection will cause spark and damage each component.

## 6. Maintenance/Adjustment

### 6.1.1 Charge Battery

- Disconnect the cable between battery and the unit, and charge the battery with a 12V battery charger. Do not charge two batteries at the same time.
- Be sure not to connect (+) and (-) terminals backwards.
- Be sure to read the operation manual of the battery charger to know if it is applicable, before using it.

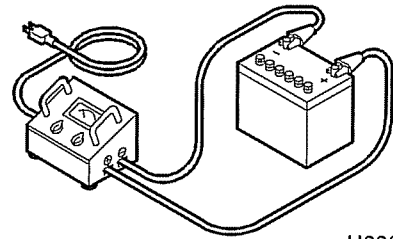

H000060

### 6.1.2 How to Use Booster Cable

**CAUTION**

***Do not connect the cable reversely***

- If a booster cable has to be used or when cables are connected at battery replacement, be careful not to connect (+) and (-) terminals backwards. Such a wrong-connection will cause spark and damage each component.

(Procedure for using a booster cable)

- ① Stop the engine.
- ② Connect one end of the (+) cable to the (+) terminal of the machine battery.
- ③ Connect the other end of the (+) cable to the (+) terminal of the external battery.
- ④ Connect one end of the (-) cable to the (-) terminal of the external battery.
- ⑤ Connect the other end of the (-) cable to the engine block of the machine.
- ⑥ Start up the engine.
- ⑦ Disconnect the booster cable by following the procedure back in the reverse order.

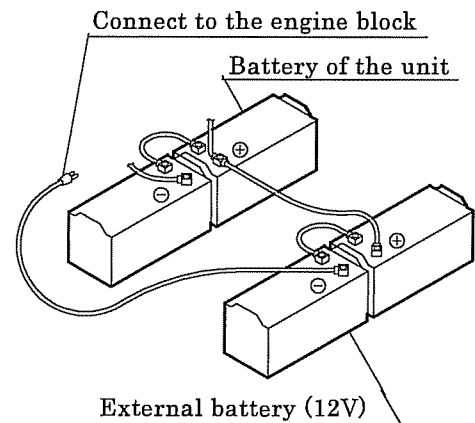

M980196E

## 6. Maintenance/Adjustment

### 6.2 Troubleshooting

- Should any trouble occur during operation, do not leave it. Investigate the cause and take appropriate measures.
- Read the manual carefully and fully understand what to do in case of trouble.
- The better you understand the construction and function of the unit, the faster you can find a problem and solution.
- This chapter describes the state, cause and countermeasures of important troubles in detail:

Symptom	Cause	Countermeasures
Low starter revolution speed.	(1) Battery malfunction.	Check battery→ Charge, change
Starter rotates but engine does not start.	(1) Fuel filter clogging. (2) Malfunction of fuel cut solenoid.	Disassemble, clean, and change Check fuse Change solenoid Check connector
Discharge air pressure does not reach FAC-185P····· 0.7MPa FACF-150P····· 1.05MPa FACG-125P····· 1.27Mpa	(1) Pressure regulator insufficient adjustment. (2) Starting unloader valve is left at its start position.	Re-adjust (Fasten)  Place it at "RUN" position
Engine does not reach its maximum speed.	(1) Improper length in speed regulator rod. (2) Unloader orifice clogging. (3) Faulty speed regulator. (4) Engine trouble. (5) Fuel filter clogging.	Re-adjust  Disassemble/Clean Disassemble/Check Call your nearest dealer Disassemble/Change
Revolution drops before discharge air pressure reaches FAC-185P····· 0.7MPa FACF-150P····· 1.05MPa FACG-125P····· 1.27Mpa	(1) Pressure regulator insufficient adjustment. (2) Trouble of pressure regulator. (3) Unloader orifice clogging.	Re-adjust (Fasten)  Change Disassemble/Check
Engine does not reach minimum revolution at unload.	(1) Improper length in speed regulator rod. (2) Faulty speed regulator.	Re-adjust Disassemble/Check
Safety valve relieves at unload.	(1) Pressure regulator insufficient adjustment. (2) Speed regulator diaphragm damaged. (3) Unloader valve damaged and seat malfunction. (4) Faulty safety valve. (5) Improper length of speed regulator rod	Re-adjust(loosen)  Change  Change Re-adjust(elongate)
Oil mixes in Air. (Poor oil separation)	(1) Scavenging orifice strainer clogging. (2) Low discharge pressure.  (3) Oil separator deteriorated.	Disassemble/Clean   Disassemble/pressure control valve/check Disassemble/Change
Insufficient free air delivery.	(1) Air filter element clogging. (2) Unloader valve cannot fully open. (3) Engine does not reach rated speed.	Clean element or change Call your nearest dealer

## 6. Maintenance/Adjustment

Symptom	Cause	Countermeasures
Engine oil pressure lamp goes on.	(1) Engine oil shortage. (2) Engine oil filter clogging. (3) Malfunction of engine oil pump (4) Faulty oil pressure switch. (5) Loosened or disconnected wiring or connector.	Replenish oil Change Change Change Check/Fasten
Coolant temp.lamp goes on.	(1) Radiator clogging. (2) Faulty thermostat. (3) Faulty coolant temp. switch. (4) Low coolant level. (5) Fan belt slippage. (6) Loose wiring, connectors and disconnection.	Clean Change Change Replenish Re-adjust tension Check/retighten
Discharge air temp. lamp goes on.	(1) Oil cooler clogging. (2) Oil filter clogging. (3) Faulty discharged air temp. switch. (4) Loose wiring connectors and disconnection. (5) Slippage of fan belt. (6) Shortage of compressor oil. (7) Malfunction of oil check valve. (8) Malfunction of by-pass valve.	Clean Change Check/inspect  Check and retighten  Re-adjust tension Replenish oil Disassemble/check Check/change
Engine speed down lamp goes on.	(1) Speed regulator insufficient adjustment. (2) Trouble of controller. (3) Shortage of feeding fuel caused due to fuel filter and gauze filter clogging (4) Air mixed in fuel line system (5) Drop of engine power output	Re-adjust  Change Replace filter and/or clean the gauze filter  Bleed the air Clean and/or replace air filter
Fuel residual level lamp goes on.	(1) Fuel runs short. (2) Malfunction of sending unit for fuel oil level drop. (3) Loosened and disconnected wiring connection and connectors.	Add fuel oil Check/ change  Check/retighten.

- Contact your nearest dealer if you find it difficult to repair by yourselves.
- Refer to the engine operation manual for trouble concerning the engine.

## 7. Storage of the Unit

---

### 7.1 Preparation for Long-term Storage

When the unit is to be kept unused in storage for a long time, be sure to follow the preparations below and put the unit in a dry and less dusty place.

- Put the unit in a temporary cabin if it is stored outside. Avoid leaving the unit outside with a sheet cover directly on the paint for a long time, or this will cause rust to the unit.
- Perform the following treatments at least once every three months.

(Procedure)

- ① Drain existing lubricant from the engine oil pan. Pour new lubricant in the engine to clean its inside. After running it for a while, drain it again.
- ② Spread lubricant on moving parts like speed regulator and rod end, beforehand.
- ③ Completely charge the battery and disconnect grounding wires. Remove the battery from the unit, if possible, and store it in a dry place. (Charge the battery at least once every month.)
- ④ Drain coolant and fuel from the unit.
- ⑤ Seal the engine, air-intake port and other openings like the muffler with a vinyl sheet, packing tape, etc., to prevent moisture and dust from getting in the unit.
- ⑥ Be sure to repair any trouble and maintain the unit so that it will be ready for the next operation.

## 8. Specifications

### 8.1 Specifications

Model		FAC-185P	FACF-150P	FACG-125P	
Compressor	Type	Single-stage oil cooled, screw type compressor			
	Free air delivery	m <sup>3</sup> /min	18.5	15	12.5
	Working pressure	MPa	0.7	1.05	1.27
	Lubricating system		Forced Lubrication by compressed pressure		
	Driving system		Direct driving with rubber coupling		
	Receiver tank capacity	m <sup>3</sup>	0.189		
	Lubricating oil capacity	L	80		
Engine	Model		Hino motors Ltd. J08C-V		
	Type		Water-cooled 4-cycle direct injection		
	Number of cylinders, bore stroke		6 – 114mm × 130 mm		
	Total displacement	L	7.961		
	Rated output	kW/min <sup>-1</sup>	118/2,500		
	Lubricating oil capacity	L	24		
	Coolant capacity (including radiator)	L	29		
	Battery		115F51 (equivalent) × 2		
	Fuel tank capacity	L	270		
	Overall length (with drawbar folded up)	mm	3,650		
	Overall length (with drawbar laid down)	mm	4,960		
	Overall width	mm	1,685		
	Overall height	mm	2,135		
	Net dry mass	kg	2,860	2,900	
	Operating mass	kg	3,200	3,240	



# 8. Specifications

## 8.2 Outline drawing

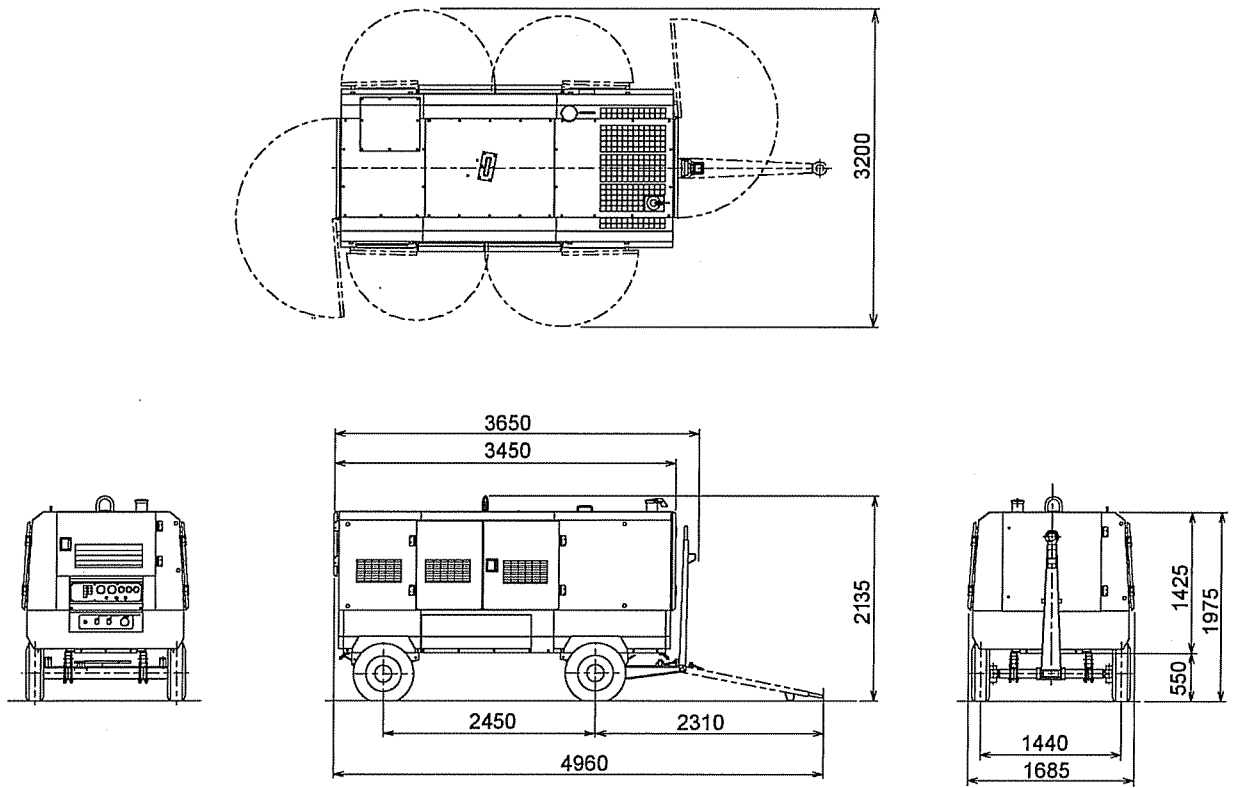

H000487E

# 9. Wiring Diagram

FAC-185P, FACF-150P

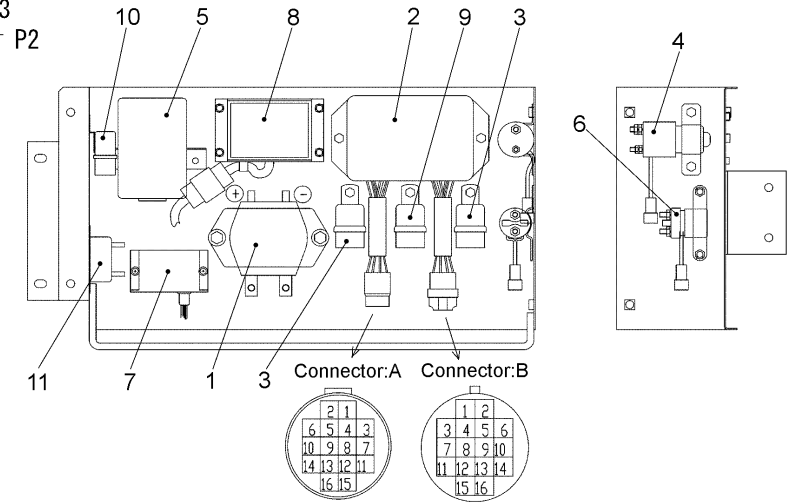
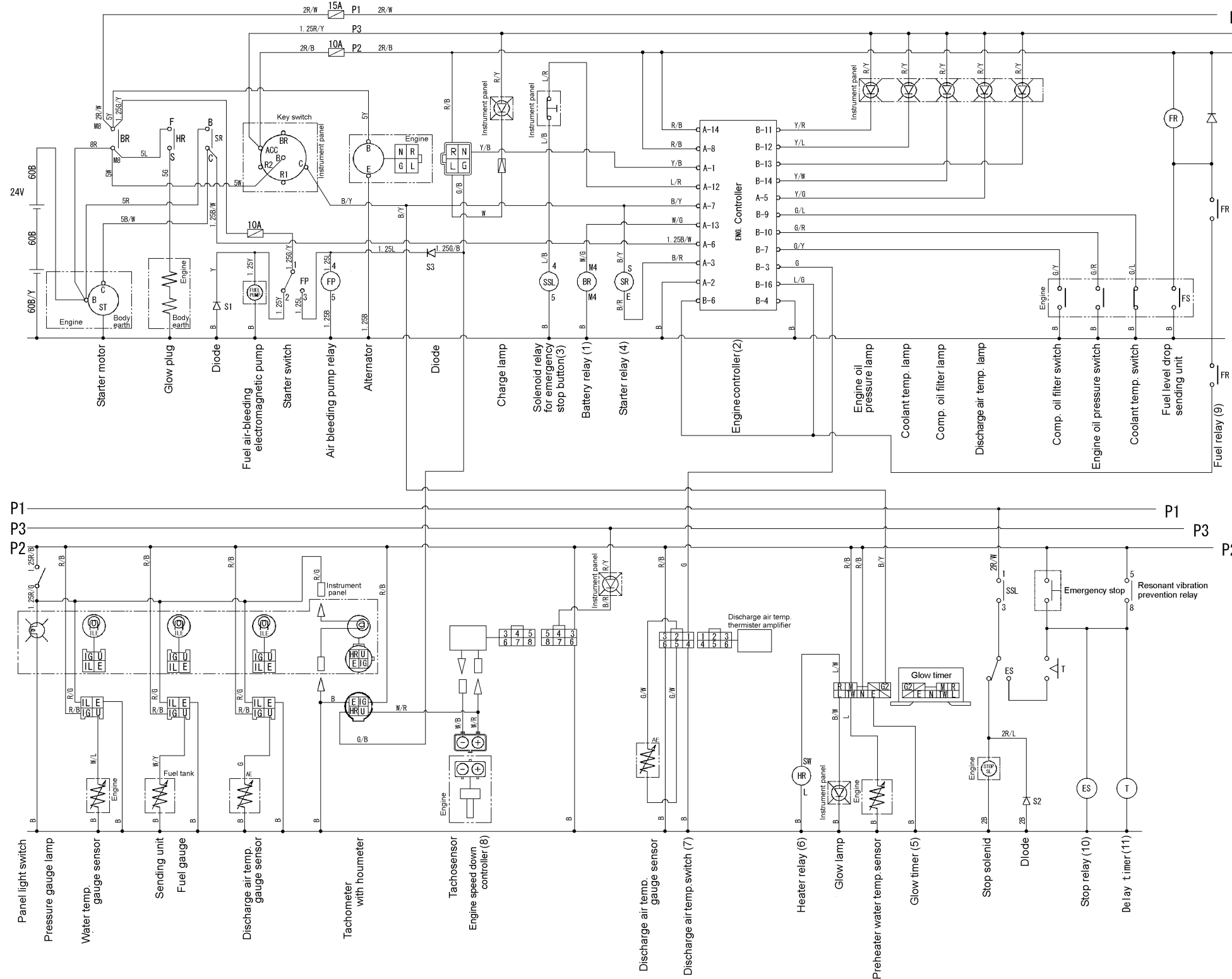

NO.	Part No.	Part Name	Type	Reference
1	44362 00400	Battery relay (BR)	HINO MOTORS 84490-1010	}
2	44390 00400	Eng. Controller (EC)	HINO MOTORS 28420-1083	
3	44346 07800	Solenoid relay (SSL)	HINO MOTORS 85920-1750	Engine
4	44338 01800	Starter relay (SR)	HINO MOTORS 28300-1190	accessory
5	44327 07500	Glow timer	HINO MOTORS 28630-1500	}
6	44364 13600	Heater relay (HR)	HINO MOTORS 28620-1420	
7	44334 13000	Discharge air temp. sw. (FAC-185P)	SAGINOMIYA CLE-D7B4-ASAF	---
	44334 12900	Discharge air temp. sw. (FACF-150P)	SAGINOMIYA CLE-D7C0-ASAF	---
8	46870 30901	Eng. speed down controller (FAC-185P)	---	---
	46870 35400	Eng. speed down controller (FACF-150P)	---	---
9	44346 07800	Fuel relay (FR)	HINO MOTORS 85920-1750	---
10	44346 04700	Stop relay (ES)	JIDECO MR5A-082-4	---
11	44327 03300	Delay timer (T)	---	---

# 9. Wiring Diagram

FACG-125P

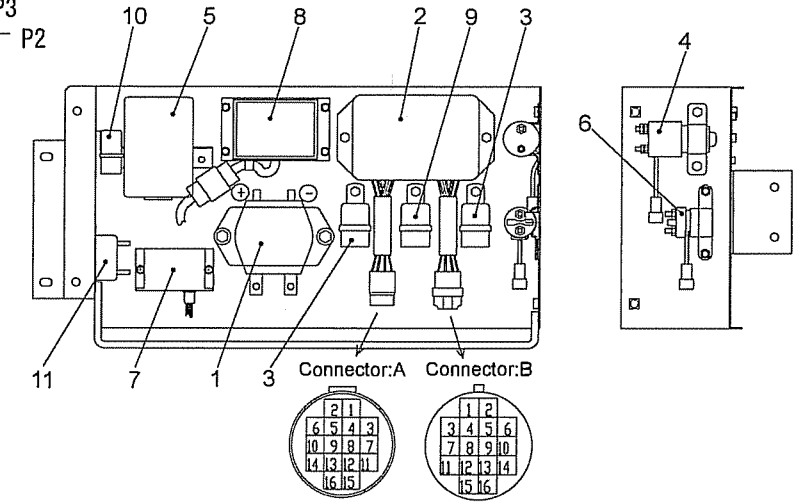
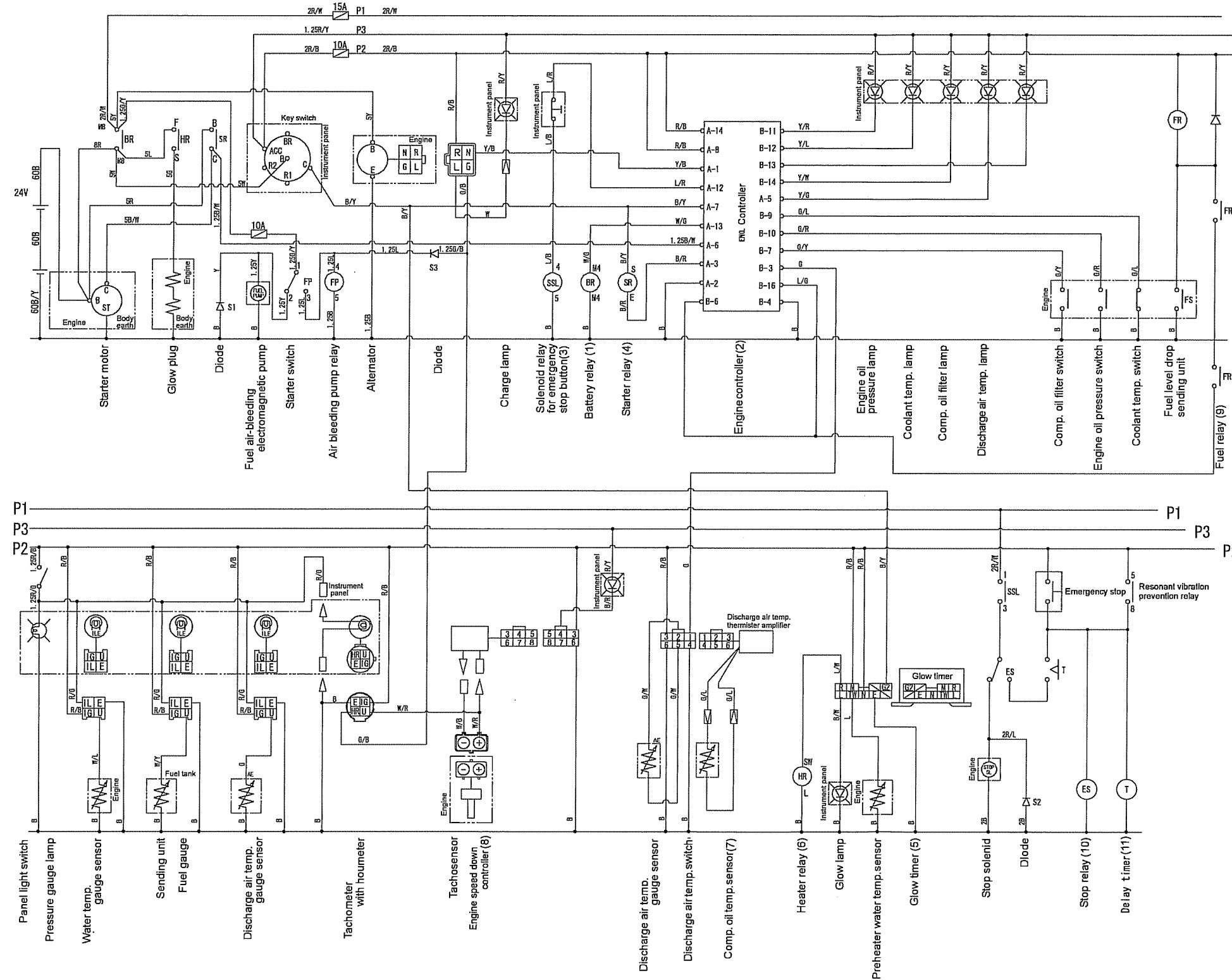

NO.	Part No.	Part Name	Type	Reference
1	44362 00400	Battery relay (BR)	HINO MOTORS 84490-1010	---
2	44390 00400	Eng. Controller (EC)	HINO MOTORS 28420-1083	---
3	44346 07800	Solenoid relay (SSL)	HINO MOTORS 85920-1750	Engine
4	44338 01800	Starter relay (SR)	HINO MOTORS 28300-1190	accessory
5	44327 07500	Glow timer	HINO MOTORS 28630-1500	---
6	44364 13600	Heater relay (HR)	HINO MOTORS 28620-1420	---
7	44334 11301	Comp.oil temp.sensor	TAKARA THERMISTOR C363-T10051	---
8	46870 30901	Eng. speed down controller	---	---
9	44346 07800	Fuel relay (FR)	HINO MOTORS 85920-1750	---
10	44346 04700	Stop relay (ES)	JIDECO MR5A-082-4	---
11	44327 03300	Delay timer (T)	---	---

# 10. Piping Diagram

FAC-185P

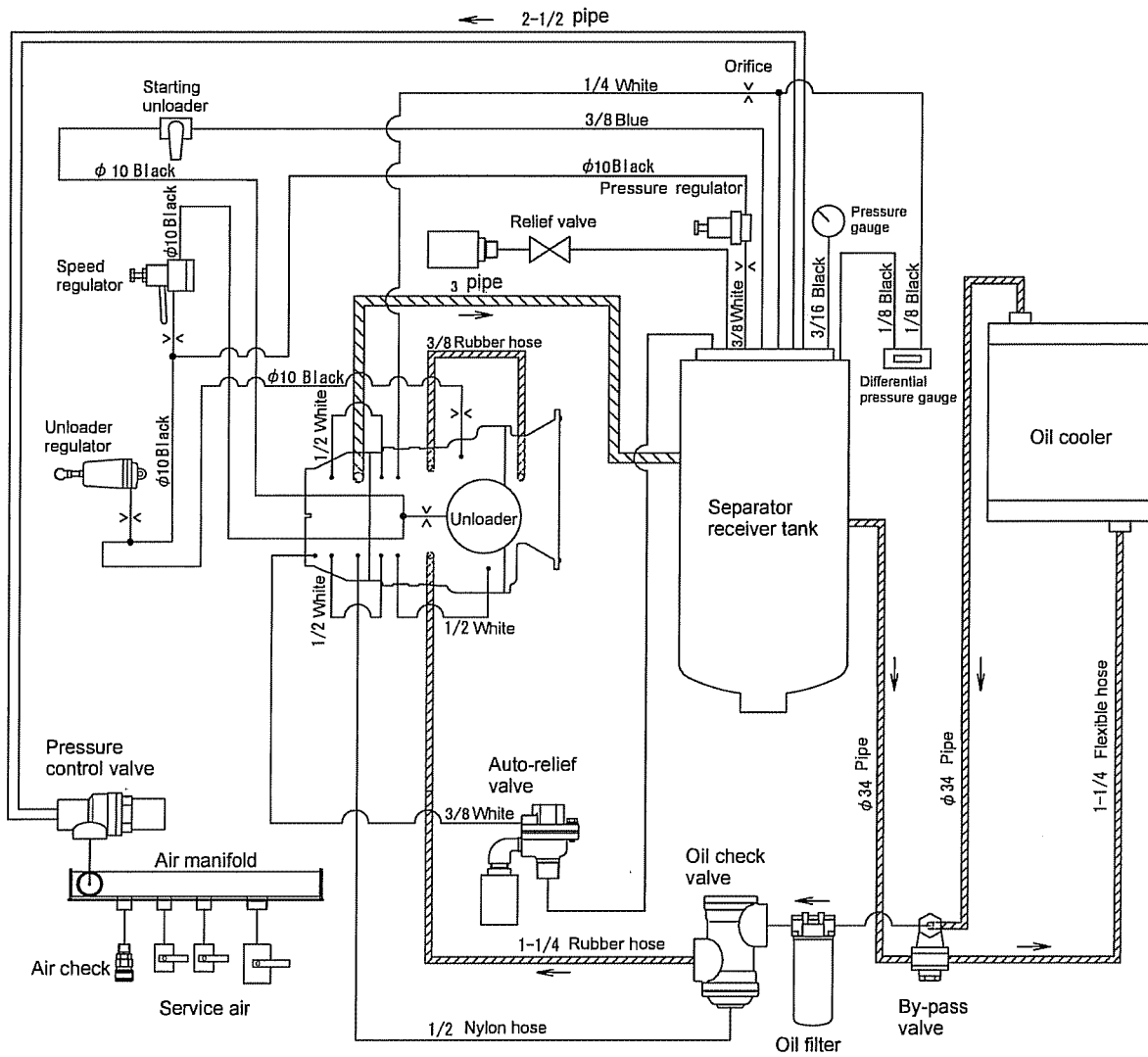

A020286E-1

# 10. Piping Diagram

FACF-150P

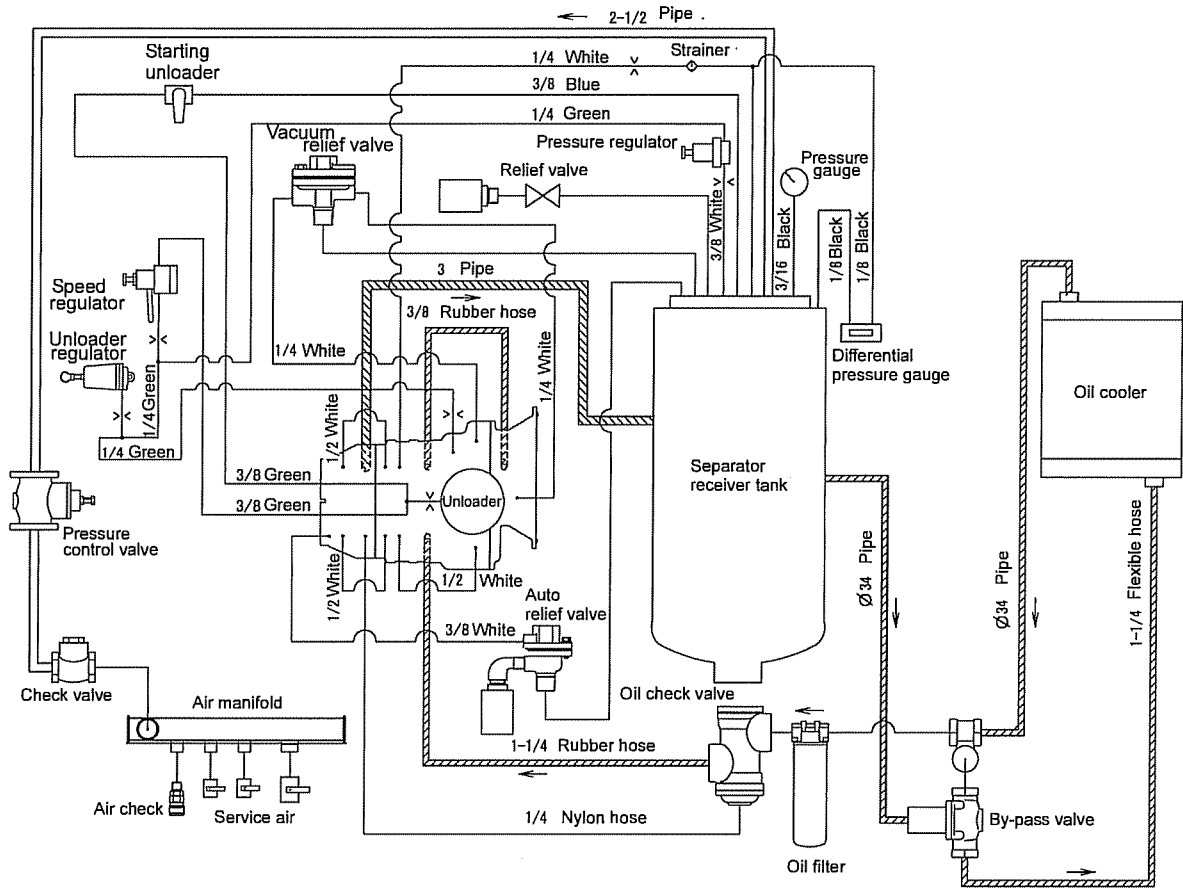

A020287E-1





Copyright (C) 2010 CURTIS-TOLEDO, INC. All Rights Reserved

**39600 11230**  
PRINTED DATE 2011. 1



