

Express Tank™ Vertical Air Receivers

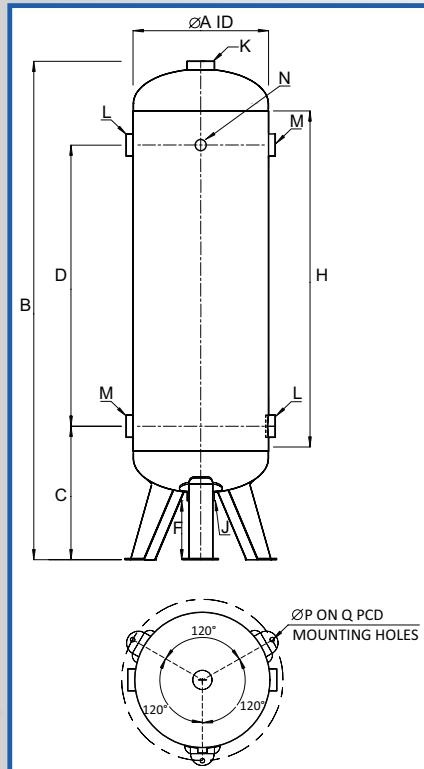

EU-V150-11-AS & EU-V300-11-AS

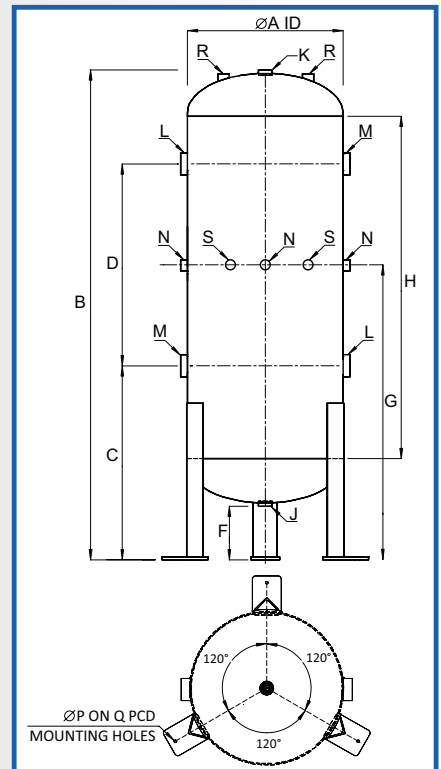

All Other Models

Air Receiver Specifications

Product Code ^Δ	Volume Litres	Design Pressure kPa	Dimensions & Weight																
			A	B	C	D	F	G	H	J	K	L	M	N	P	Q	R	S	Wt. kg
EU-V60-14-GB	60	1,400	300	1,195	515	430	248	n/a	730	1/2	n/a	3/4	3/4	n/a	14	280	1/4	n/a	35
EU-V150-11-AS	150	1,100	390	1,500	392	825	173	n/a	998	2 *	2 #	1-1/2	1-1/2	1/2	13	473	n/a	n/a	53
EU-V150-14-GB	150	1,400	400	1,603	752	350	254	997	1,050	1/2	3/4	1-1/2	1-1/2	n/a	14	418	n/a	1/2	65
EU-V300-11-AS	300	1,100	490	1,900	537	940	162	n/a	1,340	2 *	2 #	1-1/2	1-1/2	1/2	13	533	n/a	n/a	121
EU-V310-14-GB	310	1,400	500	1,994	757	780	254	1,687	1,380	1/2	3/4	1-1/2	1-1/2	n/a	14	519	n/a	1/2	126
EU-V500-11-AS	500	1,100	590	2,190	925	900	313	1,375	1,440	2 *	2 #	2	2	1/2	17	730	n/a	n/a	161
EU-V570-14-GB	570	1,400	650	2,144	822	750	254	1,201	1,455	1/2	3/4	2	2	n/a	18	661	n/a	1/2	187
EU-V800-11-AS	800	1,100	700	2,600	1,010	1,050	313	1,535	1,800	2 *	2 #	2	2	1/2	17	860	n/a	n/a	279
EU-V800-14-GB	800	1,400	750	2,220	875	720	248	1,235	1,473	3/4	3/4	2	2	n/a	18	762	n/a	1/2	228
EU-V1000-11-AS	1,000	1,100	800	2,490	1,105	1,050	313	1,630	1,670	2 *	2 #	2	2	1/2	17	980	n/a	n/a	319
EU-V1200-11-GB	1,200	1,100	950	2,181	900	837	247	1,236	1,340	3/4	1	2	2	n/a	18	962	n/a	3/4	294
EU-V1200-14-GB	1,200	1,400	950	2,181	900	837	247	1,236	1,340	3/4	1	2	2	n/a	18	962	n/a	3/4	349
EU-V2000-11-AS	2,000	1,100	1,100	2,664	730	1,500	300	1,700	1,665	1	1-1/4	NPS 3	n/a	1/2	17	1,350	n/a	n/a	656
EU-V2400-14-GB	2,400	1,400	1,100	3,114	1,017	1,250	253	1,517	2,100	1	1	NPS 3	NPS 3	n/a	20	1,101	n/a	1	747
EU-V5150-14-GB	5,150	1,400	1,450	3,720	1,097	1,780	252	1,597	2,580	1	1	NPS 4	NPS 4	n/a	24	1,482	n/a	1	1,561

* Drain valve and inspection port.
Safety valve and inspection port.
Δ AS denotes AS 1210 Standard.
GB denotes GB 150 Standard.

Compressed Air Storage: -10°C~120°C or 0°C~100°C.
Duty: Stationary applications only.
Sockets: BSP (British Standard Pipe).
Dedicated Inspection Openings: Not shown for clarity.

Nitrogen Storage: -10°C~90°C or 0°C~90°C.
Material: Carbon steel.
Flanges: Class 150 per ASME B16.5.

Express Tank vertical air receivers are designed and manufactured to the highest quality standards for safe and reliable use in industrial compressed air systems. This off-the-shelf range includes the most popular sizes from 60 to 5,150 litres that are finish-painted and packed ready for dispatch.

Features and Benefits

- Designed and manufactured in accordance with the AS/NZS 1200:2015 Pressure Equipment Standard.
- Work Health and Safety Registered Design approved for use in all Australian States and Territories.
- Convenient nozzle sizes and positions. Reinforced vessel support attachments.
- External surfaces chemical or abrasive blast cleaned and then powder coated or spray painted.
- Azure Blue RAL 5009 external colour indicates compressed air content as per industry practice.
- Individually packed in a horizontal position inside a recyclable metal crate with plastic bag dust cover.



Certified Quality Management System

Accessories

WHS regulations stipulate that each air receiver must be fitted with a safety valve, pressure gauge and drain valve. These items can be purchased in a model-specific accessory kit.

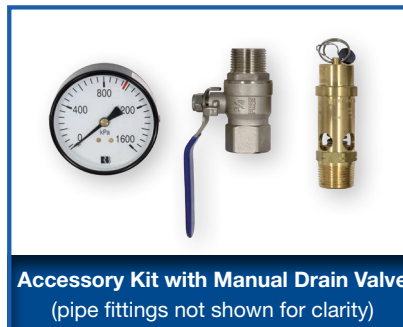

Accessory Kit Specifications

Product Code		Safety Valve			Pressure Gauge		Manual Drain Valve		Auto Drain Valve	
Manual Drain Valve Accessory Kit	Auto-Float Drain Valve Accessory Kit	Pressure	Flowrate	Size	Range	Dial Dia.	Inlet	Outlet	Inlet	Outlet
		kPa	m ³ /min	inch	kPa	mm	inch	inch	inch	inch
GM EU-V60-14-GB-K	n/a	1,400	4.98	1/4	2,500	63	1/2	1/2	n/a	n/a
GM EU-V150-11-AS-K	n/a	1,100	8.30	1/2	1,600	80	1/2	1/2	n/a	n/a
GM EU-V150-14-GB-K	n/a	1,400	10.40	1/2	2,500	80	1/2	1/2	n/a	n/a
GM EU-V300-11-AS-K	n/a	1,100	8.30	1/2	1,600	80	1/2	1/2	n/a	n/a
GM EU-V310-14-GB-K	n/a	1,400	10.40	1/2	2,500	80	1/2	1/2	n/a	n/a
GM EU-V500-11-AS-K	GM EU-V500-11-AS-ADK	1,100	8.30	1/2	1,600	80	1/2	1/2	1/2	1/8
GM EU-V570-14-GB-K	n/a	1,400	10.40	1/2	2,500	80	1/2	1/2	n/a	n/a
GM EU-V800-11-AS-K	GM EU-V800-11-AS-ADK	1,100	8.30	1/2	1,600	80	3/4	3/4	1/2	1/8
GM EU-V800-14-GB-K	n/a	1,400	10.40	1/2	2,500	80	3/4	3/4	n/a	n/a
GM EU-V1000-11-AS-K	GM EU-V1000-11-AS-ADK	1,100	18.00	3/4	1,600	80	3/4	3/4	1/2	1/8
GM EU-V1200-11-GB-K	GM EU-V1200-11-GB-ADK	1,100	18.00	3/4	1,600	80	3/4	3/4	1/2	1/8
GM EU-V1200-14-GB-K	n/a	1,390	22.30	3/4	2,500	80	3/4	3/4	n/a	n/a
GM EU-V2000-11-AS-K	GM EU-V2000-11-AS-ADK	1,100	38.20	1	1,600	80	1	1	1/2	1/8
GM EU-V2400-14-GB-K	n/a	1,400	48.00	1	2,500	80	1	1	n/a	n/a
GM EU-V5150-14-GB-K	n/a	1,400	48.00	1	2,500	80	1	1	n/a	n/a

Express Tank™

www.expresstank.com.au



Specifications are subject to change without notice. 2023-11-29